



SERVICE MANUAL

VHF FM TRANSCEIVER

IC-F310

IC-F310S

IC-F320

IC-F320S

INTRODUCTION

This service manual describes the latest service information for the **IC-F310, IC-F310S, IC-F320 and IC-F320S** VHF FM TRANSCEIVER at the time of publication.

To upgrade quality, any electrical or mechanical parts and internal circuits are subject to change without notice or obligation.

DANGER

NEVER connect the transceiver to an AC outlet or to a DC power supply that uses more than 16 V. This will ruin the transceiver.

DO NOT expose the transceiver to rain, snow or any liquids.

DO NOT reverse the polarities of the power supply when connecting the transceiver.

DO NOT apply an RF signal of more than 20 dBm (100 mW) to the antenna connector. This could damage the transceiver's front end.



ORDERING PARTS

Be sure to include the following four points when ordering replacement parts:

1. 10-digit order numbers
2. Component part number and name
3. Equipment model name and unit name
4. Quantity required

<SAMPLE ORDER>

1150001930 IC SC-1364 IC-F310 MAIN UNIT 5 pieces
8810005840 Screw PHBT M3 x 8 NI-ZU IC-F310 Bottom cover 10 pieces

Addresses are provided on the inside back cover for your convenience.

REPAIR NOTES

1. Make sure a problem is internal before disassembling the transceiver.
2. **DO NOT** open the transceiver until the transceiver is disconnected from its power source.
3. **DO NOT** force any of the variable components. Turn them slowly and smoothly.
4. **DO NOT** short any circuits or electronic parts. An insulated tuning tool **MUST** be used for all adjustments.
5. **DO NOT** keep power ON for a long time when the transceiver is defective.
6. **DO NOT** transmit power into a signal generator or a sweep generator.
7. **ALWAYS** connect a 50 dB to 60 dB attenuator between the transceiver and a deviation meter or spectrum analyzer when using such test equipment.
8. **READ** the instructions of test equipment thoroughly before connecting equipment to the transceiver.

EXPLICIT DEFINITIONS

VERSIONS

F320/F320S	LMR (Land Mobile Radio)	U.S.A. version
F310/F310S	PMR (Personal Mobile Radio)	European version

FREQUENCY COVERAGE

L-band	136–155 MHz
H-band	146–174 MHz

CHANNEL SPACING

Wide/Narrow-type	25 kHz/12.5 kHz
------------------	-----------------

TABLE OF CONTENTS

SECTION 1	SPECIFICATIONS	
SECTION 2	INSIDE VIEW	
SECTION 3	DISASSEMBLY INSTRUCTIONS	
SECTION 4	CIRCUIT DESCRIPTION	
4 - 1	RECEIVER CIRCUITS	4 - 1
4 - 2	TRANSMITTER CIRCUITS	4 - 2
4 - 3	PLL CIRCUITS	4 - 3
4 - 4	POWER SUPPLY CIRCUITS	4 - 4
4 - 5	PORT ALLOCATIONS	4 - 4
SECTION 5	ADJUSTMENT PROCEDURES	
5 - 1	PREPARATION	5 - 1
5 - 2	PLL ADJUSTMENT	5 - 3
5 - 3	TRIMMER ADJUSTMENT	5 - 4
5 - 4	BEEP ADJUSTMENT	5 - 5
SECTION 6	PARTS LIST	
SECTION 7	MECHANICAL PARTS	
SECTION 8	SEMI-CONDUCTOR INFORMATION	
SECTION 9	BOARD LAYOUTS	
9 - 1	FRONT UNIT (IC-F310/F320)	9 - 1
9 - 2	FRONT UNIT (IC-F310S/F320S)	9 - 3
9 - 3	MAIN UNIT (IC-F310/F310S)	9 - 5
9 - 4	MAIN UNIT (IC-F320/F320S)	9 - 7
SECTION 10	BLOCK DIAGRAM	
SECTION 11	VOLTAGE DIAGRAM	
11 - 1	FRONT UNIT	11 - 1
11 - 2	MAIN UNIT	11 - 2

SECTION 1 SPECIFICATIONS

		IC-F310/F310S (PMR)	IC-F320/F320S (LMR)	
GENERAL	Mesurement method	ETS 300 086	EIA/TIA-152C/204D	
	Frequency coverage	136–155 MHz 146–174 MHz		
	Number of channels	F310 : 32 (16 ch × 2 banks)	F320 : 32 (16 ch × 2 banks)	
		F310S: 8 ch, or 4 ch × 2 banks	F320S: 4 ch	
	Type of emission	16K0F3E (25 kHz; Wide) 8K50F3E (12.5 kHz; Narrow)		
	Frequency stability	±1500 Hz	±0.0005%	
	Operating temperature range	–20°C to +55°C	–30°C to +60°C; –22°F to +140°F	
	Power supply voltage	13.2 V DC (negative ground)	13.6 V DC (negative ground)	
	Current drain (approx.)	TX max. power	7.0 A (at 25 W) / 6.0 A (at 10 W)	
		RX	max. audio	700 mA
			stand-by	200 mA
	Antenna connector	SO-239 (50 Ω)		
Dimensions (proj. not included)	140(W) × 40(H) × 170(D) mm; 5½(W) × 1⅞(H) × 6⅞(D) inch			
Weight	1.2 kg; 2 lb 10 oz			
TRANSMITTER	Output power	25 W / 10 W	45 W	
	Modulation system	Variable reactance frequency modulation		
	Max. frequency deviation	±5.0 kHz (Wide) ±2.5 kHz (Narrow)		
	Spurious emissions	0.25 μW	70 dB	
	Adjacent channel power	70 dB minimum (Wide) 60 dB minimum (Narrow)		
	Residual modulation	55 dB typical (Wide) 50 dB typical (Narrow)	46 dB typical (Wide) 40 dB typical (Narrow)	
	Limiting charact of modulator	70–100 % of modulation		
	Microphone connector	8-pin modular (600 Ω)		
RECEIVER	Intermediate frequency	1st: 31.05 MHz 2nd: 450 kHz		
	Sensitivity	–4 dBμV (emf) at 20 dB SINAD	0.22 μV typical at 12 dB SINAD	
	Squelch sencitivity	–4 dBμV (emf)	0.22 μV typical	
	Adjcent chnnel selectivity	70 dB (Wide) 60 dB (Narrow)		
	Spurious response	70 dB		
	Intermoduration	65 dB		
	Hum and noise	55 dB typical (Wide) 50 dB typical (Narrow)	46 dB typical (Wide) 40 dB typical (Narrow)	
	Audio output power	3.5 W typical at 10% distortion with a 4 Ω load		
	External SP connector	2-conductor 3.5 (d) mm (⅛")/4 Ω		

All stated specifications are subject to change without notice or obligation.

SECTION 2

INSIDE VIEW

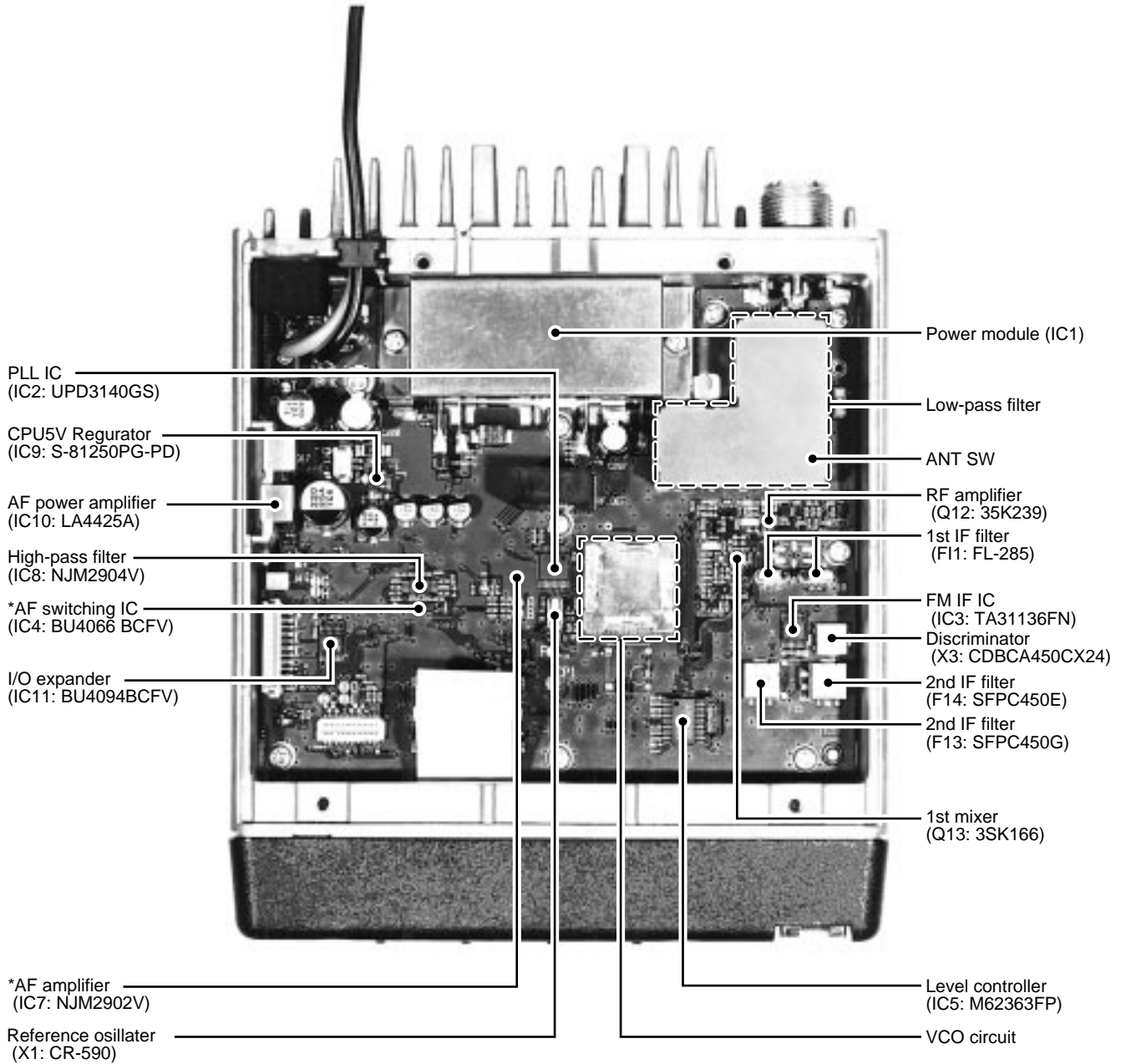

Note:

*Located under side of the point.

SECTION 3 DISASSEMBLY INSTRUCTIONS

- Opening case

- ① Unscrew 4 screws, (A), and remove the bottom cover.
- ② Unscrew 2 screws, (B), and remove the front case.

- ⑥ Lift the front portion of the main unit and remove it.

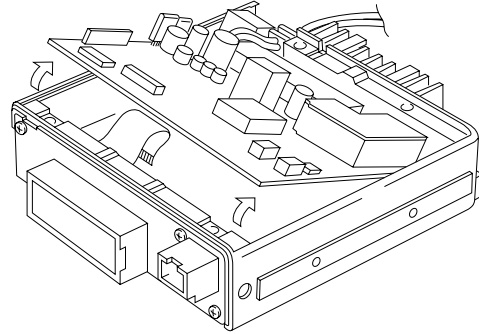
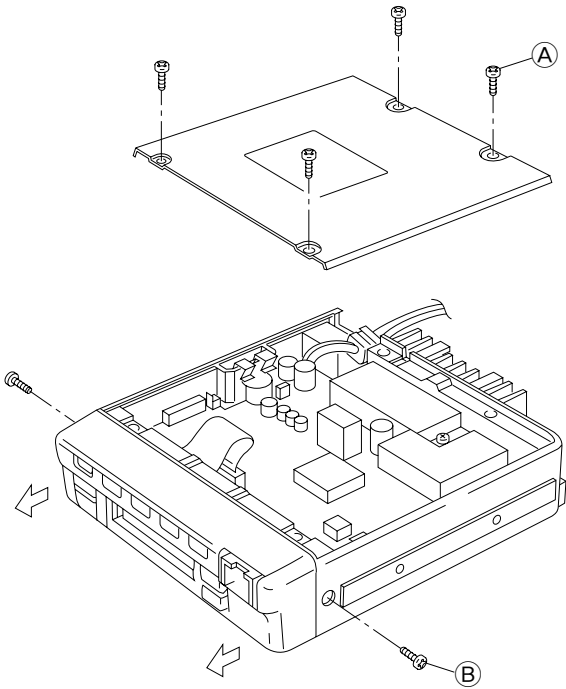

- Instration location
 UT-96 TONE UNIT
 UT-105 SmarTrank 2™ Logic Board

- ③ Unscrew 10 screws, (C), and remove 2 clips, (D).
- ④ Remove shield case, (E).
- ⑤ Unsolder 3 points, (F), from the antenna connector.

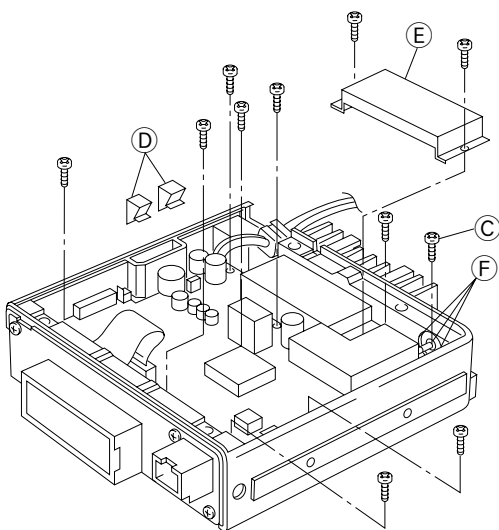
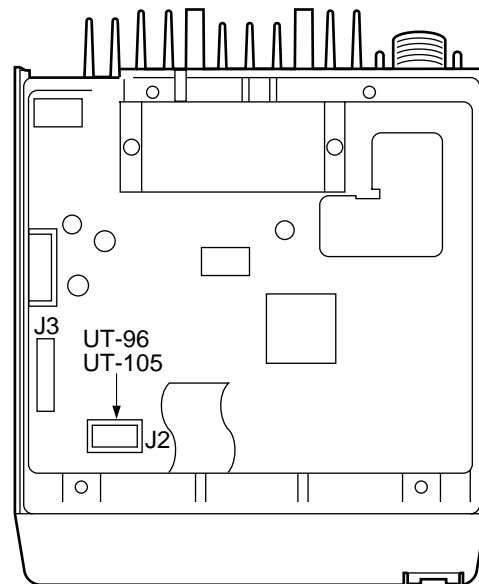

SECTION 4 CIRCUIT DESCRIPTION

4-1 RECEIVER CIRCUITS

4-1-1 ANTENNA SWITCHING CIRCUIT (MAIN unit)

The antenna switching circuit functions as a low-pass filter while receiving and as resonator circuit while transmitting. The circuit does not allow transmit signals to enter receiver circuits.

Received signals enter the antenna connector and pass through the low-pass filter (L1–L3, C1, C3, C8–C11, C13). The filtered signals are then applied to the RF circuit passed through the $\lambda/4$ type antenna switching circuit (D13, D14, L18).

4-1-2 RF CIRCUIT (MAIN unit)

The RF circuit amplifies signals within the range of frequency coverage and filters out-of-band signals.

The signals from the antenna switching circuit pass through the attenuator circuit (D13, D14) and the two-stage tunable bandpass filters (D16, D17). The filtered signals are amplified at the RF amplifier (Q12) and then enter the another two-stage bandpass filters (D18–D21) to suppress unwanted signals. The filtered signals are applied to the 1st mixer circuit (Q13).

The tunable bandpass filters (D16–D21) employ varactor diodes to tune the center frequency of the RF passband for wide bandwidth receiving and good image response rejection. These diodes are controlled by the CPU (FRONT unit; IC1) via the level controller (IC5).

The attenuator circuit (D13, D14) functions only when the attenuator function is assigned to a programable key and turns on to protect the RF amplifier from distortion caused by receiving excessively strong signals.

When the attenuator function is turned on, CPU (FRONT unit; IC1, pin 32) switches the voltage level of the “RF ATT” line from high to low and then controls the attenuator switch (Q35). In this case, the current of D13, D14 is increased and D13, D14 act as an attenuator.

4-1-3 1ST MIXER AND 1ST IF CIRCUITS (MAIN unit)

The 1st mixer circuit converts the received signals to a fixed frequency of the 1st IF signal with the PLL output frequency. By changing the PLL frequency, only the desired frequency will pass through a pair of crystal filters at the next stage of the 1st mixer.

The RF signals from the bandpass filter are applied to the 1st mixer circuit (Q13). The applied signals are mixed with the 1st LO signal coming from the VCO circuit (Q7, Q8) to produce a 31.05 MHz 1st IF signal. The 1st IF signal passes through a pair of crystal filters (F1a/b) to suppress out-of-band signals. The filtered signal is amplified at the 1st IF amplifier (Q14) and applied to the 2nd IF circuit.

4-1-4 2ND IF AND DEMODULATOR CIRCUITS (MAIN unit)

The 2nd mixer circuit converts the 1st IF signal to a 2nd IF signal. A double-conversion superheterodyne system improves the image rejection ratio and obtains stable receiver gain.

The 1st IF signal from the IF amplifier (Q14) is applied to the 2nd mixer section of the FM IF IC (IC3, pin 16) and is then mixed with the 2nd LO signal for conversion to a 450 kHz 2nd IF signal.

IC3 contains the 2nd mixer, limiter amplifier, quadrature detector, active filter and noise amplifier circuits, etc. A doubled frequency from the PLL reference oscillator is used for the 2nd LO signal (30.6 MHz).

The 2nd IF signal from the 2nd mixer (IC3, pin 3) passes through ceramic filters (F13 and F14) during narrow channel spacing selection or passes through F14 (bypassing F13) only during wide channel spacing selection. It is then amplified at the limiter amplifier section (IC3, pin 5) and applied to the quadrature detector section (IC3, pins 10, 11 and X3) to demodulate the 2nd IF signal into AF signals.

The AF signals are output from pin 9 (IC3) and are then applied to the AF amplifier circuit.

• 2nd IF and demodulator circuits

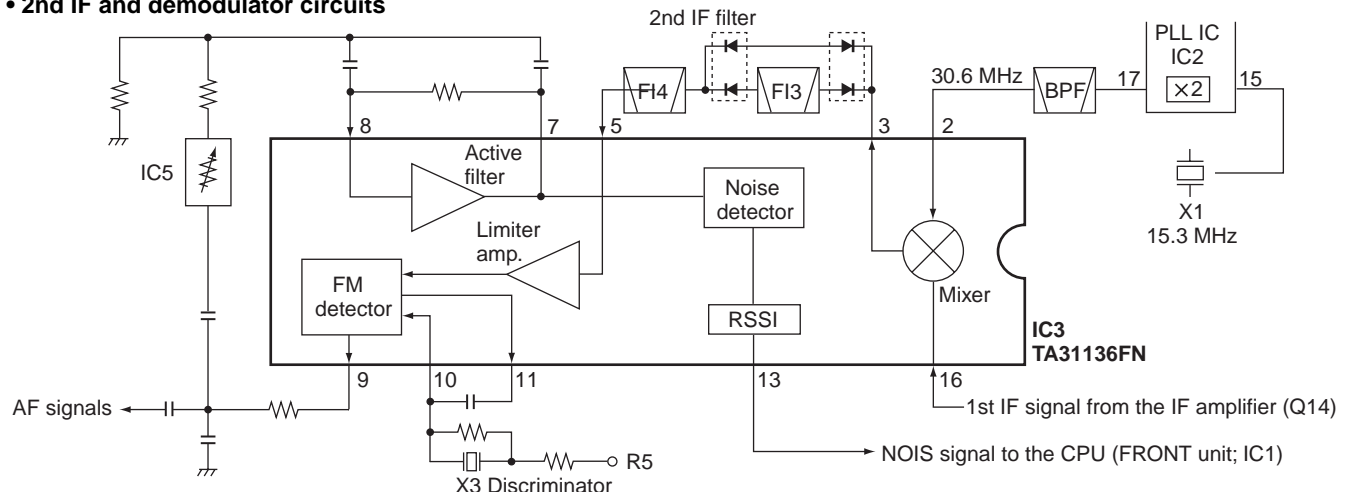

4-1-5 AF AMPLIFIER CIRCUIT (MAIN unit)

The AF amplifier circuit amplifies the demodulated AF signals to drive a speaker.

AF signals from the FM IF IC (IC3, pin 9) are amplified at the AF amplifier (IC7a) and then pass through the AF switching IC (IC4, pins 1, 2) and high-pass filter (IC8) whose characteristics are controlled by the "AFHPF" line. When "AFHPF" is at a high level, the cut off frequency is shifted higher to remove CTCSS or DTCS signals.

The filtered signals from IC8 (pin 7) are amplified at the limiter (IC7b) and buffer (IC7c) amplifiers, and passed through the de-emphasis circuit (R145, C182) with frequency characteristics of -6 dB/octave, and are then applied to the level controller (IC5). The audio level controlled signals are passed through the low-pass filter (IC6b) and AF switching IC (IC4, pins 8, 9), and are then power amplified at the AF amplifier (IC10) to drive a speaker via the buffer amplifier (IC6d).

4-1-6 RECEIVER MUTE CIRCUITS (MAIN and FRONT units)

• NOISE SQUELCH

The noise squelch circuit cuts out AF signals when no RF signals are received. By detecting noise components in the AF signals, the squelch circuit switches the AF mute switch.

A portion of the AF signals from the FM IF IC (IC3, pin 9) are applied to the level controller (IC5, pin 24). The level controlled noise components are output from pin 23 and are applied to the active filter in IC3 (pin 8). Noise components of about 10 kHz are amplified and output from pin 7 and are then applied to the noise detector section (pins 10, 11). The detected noise signals are rectified and output from pin 13 without smoothing.

The noise signal (NOIS) from IC3 (pin 13) is applied to the CPU (FRONT unit; IC1, pin 19). The CPU analyzes the noise condition and outputs the RMUT signal via the I/O expander IC (IC11) to toggle the AF mute switches (IC4a/c).

• CTCSS AND DTCS

The tone squelch circuit detects AF signals and opens the squelch only when receiving a signal containing a matching subaudible tone (CTCSS or DTCS). When tone squelch is in use, and a signal with a mismatched or no subaudible tone is received, the tone squelch circuit mutes the AF signals even when noise squelch is open.

• AF circuit

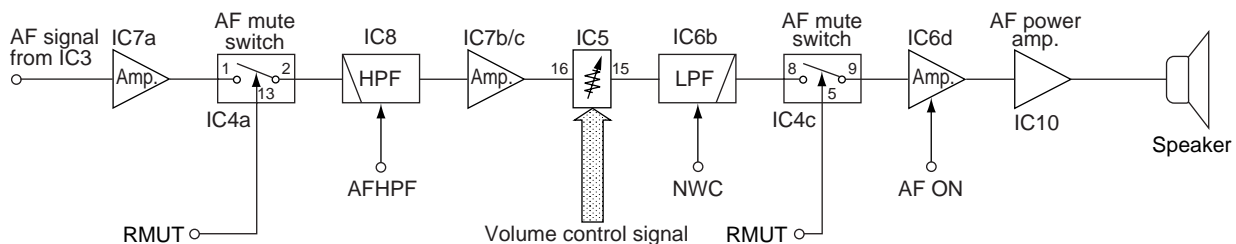

A portion of the AF signals from the AF amplifier (IC7a) passes through the low-pass filter (FRONT unit; Q5) to remove AF (voice) signals and is applied to the CTCSS or DTCS decoder inside the CPU (FRONT unit; IC1, pin 97) via the "CTCIN" line to control the AF mute switch via the I/O expander IC (IC11).

4-2 TRANSMITTER CIRCUITS

4-2-1 MICROPHONE AMPLIFIER CIRCUIT (MAIN unit)

The microphone amplifier circuit amplifies the audio signals from the microphone, within +6 dB/octave pre-emphasis characteristics, to a level needed for the modulation circuit.

The AF signals from the microphone are amplified at the AF amplifier (IC7d) and are then passed through the pre-emphasis circuit (R172, C295) which has +6 dB/octave pre-emphasis characteristics.

The pre-emphasized signals are applied to the AF switching IC (IC4, pins 4, 3), and are then passed through the high-pass filter (IC8a/b). The filtered signals are amplified at the limiter (IC7b) and buffer (IC7c) amplifiers.

The signals are applied to the level controller (IC5, pins 16, 15). The deviation level controlled signals are passed through the splatter filter (IC6b) and AF switching IC (IC4, pins 11, 10), and are then applied to modulation circuit as the "MOD" signal.

The narrow/wide switch (Q21) is connected to the input of the splatter filter (IC6b) and switched by the "NWC" signal coming from the I/O expander IC (IC11). When "NWC" is at a high level, the narrow/wide switch (Q21) shifts the filter cut-off frequency for narrow deviation selection.

4-2-2 MODULATION CIRCUIT (MAIN unit)

The modulation circuit modulates the VCO oscillating signal (RF signal) using the microphone AF signals.

The "MOD" signals from the AF switching IC (IC4, pin 10) change the reactance of D9 to modulate the oscillated signal at the VCO circuit (Q7, Q8). The modulated signal is amplified at the buffer amplifiers (Q6, Q4) and is then applied to the drive amplifier circuit.

4-2-3 DRIVE AMPLIFIER CIRCUIT (MAIN unit)

The drive amplifier circuit amplifies the VCO oscillating signal to the level needed at the power amplifier.

The RF signal from the buffer amplifier (Q4) passes through the T/R switch (D5) and is amplified at the buffer (Q3, Q2) and drive (Q1) amplifiers. The amplified signal is applied to the power amplifier circuit.

4-2-4 POWER AMPLIFIER CIRCUIT (MAIN unit)

The power amplifier circuit amplifies the driver signal to an output power level.

The RF signal from the drive amplifier (Q1) is applied to the power module (IC1) to obtain 45 W (for IC-F320; 25 W for IC-F310) of RF power.

The amplified signal is passed through the antenna switching circuit (D3, D4), low-pass filter and APC detector, and is then applied to the antenna connector.

Collector voltages for the driver (Q1) and control voltage for the power amplifier (IC1, pin 2) come from APC controller (Q17, Q18) to stabilize the output power. The transmit mute switch (Q23) controls the APC controller when transmit mute is necessary.

4-2-5 APC CIRCUIT (MAIN unit)

The APC circuit protects the power amplifier from a mismatched output load and stabilize the output power.

The APC detector circuit (D1, D2) detects forward signals and reflection signals at D2 and D1 respectively. The combined voltage is at minimum level when the antenna impedance is matched at 50 Ω and is increased when it is mismatched.

The detected voltage is applied to the inverse amplifier (IC6c, pin 9), and the power setting voltage (T4) is applied to the other input (pin 10) for the reference. When antenna impedance is mismatched, the detected voltage exceeds the power setting voltage. The output voltage of the inverse amplifier (IC6c, pin 8) controls the input current of the power module (IC1) and drive amplifier (Q1) to reduce the output power via the APC controller (Q17, Q18).

4-3 PLL CIRCUITS

4-3-1 PLL CIRCUIT

A PLL circuit provides stable oscillation of the transmit frequency and receive 1st LO frequency. The PLL circuit consists of the PLL IC (IC2), loop filter and reference oscillator circuit and employs a pulse swallow counter.

An oscillated signal from the VCO (Q7, Q8) passes through the buffer amplifiers (Q6, Q5) is applied to the PLL IC (IC2, pin 2) and is prescaled in the PLL IC based on the divided ratio (N-data). The reference signal is generated at the reference oscillator (X1) and is also applied to the PLL IC. The PLL IC detects the out-of-step phase using the reference frequency and outputs it from pin 8. The output signal is passed through the loop filter (R43–R45, C60, C61) and is then applied to the VCO circuit as the lock voltage.

4-3-2 VCO CIRCUIT (MAIN unit)

The VCO oscillated signal is amplified at the buffer amplifiers (Q6, Q4) and is then applied to the T/R switching circuit (D5, D6). The Rx signal is applied to the 1st mixer circuit (Q13) via the bandpass filter (L23, L24, C116–C118) and the Tx signal to the driver (Q1) via the buffer amplifiers (Q2, Q3).

A portion of the signal from Q6 is amplified at the buffer amplifier (Q5) and is then fed back to the PLL IC (IC2 pin 2).

• PLL circuit

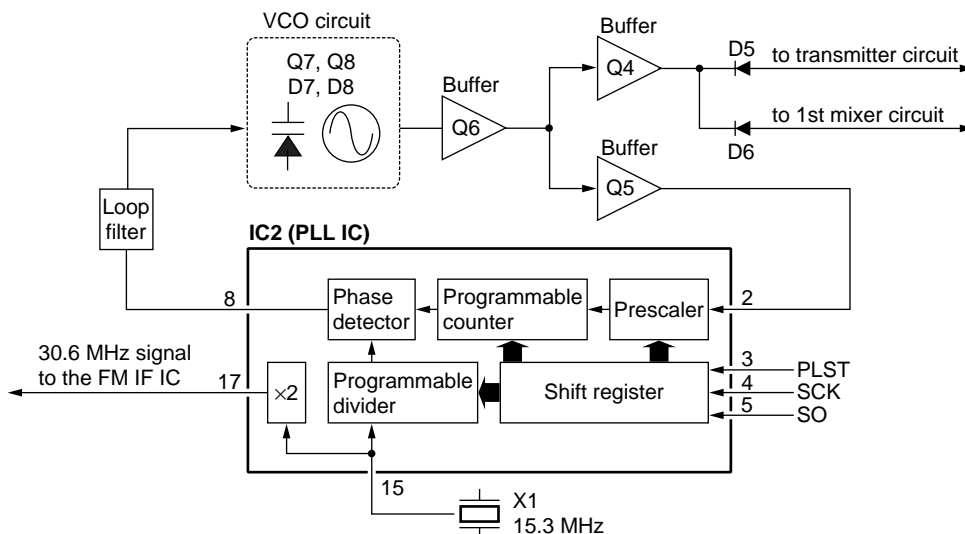

4-4 POWER SUPPLY CIRCUITS

4-4-1 VOLTAGE LINES (MAIN unit)

Line	Description
VCC	The voltage from a DC power supply.
HV	The same voltage as the VCC line which is controlled by the power switching circuit (Q25, Q26). When the [POWER] switch is pushed, the CPU outputs the "PWON" control signal to the power switching circuit to turn the circuit ON.
CPU5V	Common 5 V for the CPU converted from the VCC line by the CPU5V regulator circuit (IC9). The circuit outputs the voltage regardless of the power ON/OFF condition.
8V	Common 8 V converted from the HV line by the 8V regulator circuit (Q36).
5V	Common 5 V converted from the VCC line by the 5V regulator circuit (Q29, Q30).
R5	Receive 5 V controlled by the R5 regulator circuit (Q27) using the "T5C" signal from the I/O expander IC (IC11).
T5	Transmit 5 V controlled by the T5 regulator circuit (Q28) using the "T5C" signal from the I/O expander IC (IC11).

4-5 PORT ALLOCATIONS

4-5-1 CPU (FRONT unit; IC1)

Pin number	Port name	Description
1	VIN	Input port for overvoltage detection from the connected power supply.
12	SCK	Outputs clock signal to the EEPROM (IC3), PLL IC (MAIN unit; IC2) and expander ICs (MAIN unit; IC5, IC11), etc.
13	SI	Input port for the data signals from the EEPROM (IC3), etc.
14	SO	Outputs data signals to the EEPROM (IC3), PLL IC (MAIN unit; IC2) and expander ICs (MAIN unit; IC5, IC11), etc.
16	CLIN	Input port for the cloning signal.
17	CLOUT	Output port for the cloning signal.
18	POSW	Input for the POWER switch. Low : While POWER switch is pushed.
19	NOIS	NOIS signal input port from the FM IF IC (MAIN unit; IC3) for noise squelch operation.
26	PTT	Input port for the PTT switch. Low : While PTT switch is pushed.

CPU (IC1)—continued

Pin number	Port name	Description
32	RFATT	Outputs RF attenuator control signal to the attenuator switch (MAIN unit; Q35). Low : While attenuator function is ON.
36	UNLK	Input port for PLL unlock signal from the PLL IC (MAIN unit; IC2). High: During unlock.
37	PWON	Outputs control signal for the power switching circuit (MAIN unit; Q25) and 5V regulator circuit (MAIN unit; Q29, Q30).
38	DIM	Outputs control signal for LCD backlight. Low : While LCD backlight is ON.
39	EXTPTT	Input port for the PTT switch from the external connector (MAIN unit; J3). Low : External PTT switch is ON.
40	DIMIN	Input port for the LCD backlight control signal from the external connector (MAIN unit; J3). Low : External dimmer switch is ON.
41	PLST	Outputs strobe signals for the PLL IC (MAIN unit; IC2).
42	DAST	Outputs strobe signals for the level controller IC (MAIN unit; IC5).
43	EXST	Outputs strobe signals for the I/O expander IC (MAIN unit; IC11).
45, 46	KS1, KS0	Output ports for the key matrix.
47-50	KR3-KR0	Input ports for the key matrix.
51	BM	Outputs control signal for the beep mute circuit (Q10). High: Beep muted.
52-54	CTDA0-CTDA2	Output port for the CTCSS/ DTCS signals.
55	HANG	Input ports for the microphone hanger detection signal. Low : Microphone on hook
90	MTONE	Output port beep audio while receiving. 2/5 tone signals while transmitting.
91	TONED	Outputs DTMF signals.
94-96	OPV3-OPV1	Input port for the option connector state (MAIN unit; J2).
97	CTCIN	Input port for the CTCSS/DTCS decode signals.
98	SD	Input port for S-meter signal.
99	LVIN	Input port for PLL lock voltage.
100	TEMP	Input port for the transceiver's internal temperature.

4-5-2 I/O expander IC

(1) IC5 (MAIN unit)

Pin number	Port name	Description
2, 3, 10	T1-T3	Output tunable band pass filter control signals.
11	T4	Output port for tunable band pass filter control signal while receiving. output power control signal while transmitting.
14	REF	Output port for reference frequency control voltage.

(2) IC11 (MAIN unit)

Pin number	Port name	Description
4	T5C	Outputs control signal for the T5 and R5 regulator circuits (MAIN unit; Q27, Q28). High: While transmitting.
5	TMUT	Outputs Tx mute switch (MAIN unit; Q19, Q23) control signal. High: While Tx is muted.
6	RM	Outputs AF mute switch (MAIN unit; IC4) control signal for the receiver circuit. High: While no receive audio is emitted.
7	MM	Outputs MIC mute control signal. High: While DTMF signals are output, etc.
11	HORNO	Outputs external device control signal. High: When matched 2/5-tone signals are received.
12	AFON	Outputs control signal for the AF amplifier regulator circuit. High: When squelch is open, etc.
13	AFHPF	Outputs AF filter control signal. High: Filters out CTCSS or DTCS frequency.
14	NWC	Outputs receive/transmit passband width control signal. High: While narrow bandwidth is selected.

SECTION 5 ADJUSTMENT PROCEDURES

5-1 PREPARATION

■ REQUIRED TEST EQUIPMENT

EQUIPMENT	GRADE AND RANGE	EQUIPMENT	GRADE AND RANGE
DC power supply	Output voltage : 13.2 (13.6) V DC Current capacity : 15 A or more	Audio generator	Frequency range : 300–3000 Hz Measuring range : 1–500 mV
RF power meter (terminated type)	Measuring range : 1–75 W Frequency range : 100–300 MHz Impedance : 50 Ω SWR : Less than 1.2 : 1	Standard signal generator (SSG)	Frequency range : 0.1–300 MHz Output level : 0.1 μV–32 mV (–127 to –17 dBm)
Frequency counter	Frequency range : 0.1–300 MHz Frequency accuracy : ±1 ppm or better Sensitivity : 100 mV or better	Oscilloscope	Frequency range : DC–20 MHz Measuring range : 0.01–20 V
		AC millivoltmeter	Measuring range : 10 mV–10 V
FM deviation meter	Frequency range : DC–300 MHz Measuring range : 0 to ±10 kHz	External speaker	Input impedance : 4 Ω Capacity : 5 W or more
DC voltmeter	Input impedance : 50 kΩ/V DC or better	Attenuator	Power attenuation : 50 or 60 dB Capacity : 100 W or more

■ ADJUSTMENT FREQUENCY DATA

Before starting the adjustment, back up the original frequency data and program adjustment frequency data at right using the optional programming software (EX-2057 Rev. 1.0 or later for IC-F310/F320, CS-F300S for IC-F310S/F320S), cloning cable (OPC-478), and adaptor cable (OPC-592) for your convenience.

• ADJUSTMENT FREQUENCY

Channel No.	L-band [MHz]	H-band [MHz]
1	155.00000	174.00000
2	136.00000	146.00000
3	146.00000	160.00000

■ TRIMMER ADJUSTMENT

When you adjust the contents on page 5-4, TRIMMER ADJUSTMENT, the optional EX-2057, OPC-478 and JIG CABLE are required.

• STARTING TRIMMER ADJUSTMENT

Turn the transceiver power ON, connect a computer to the [MIC] jack using the optional OPC-478 CLONING CABLE and JIG CABLE, then start up the "ADJUST" program in EX-2057 or CS-F300S.

• STARTING THE PROGRAM

- 1 Boot up DOS.
- 2 Insert the EX-2057 or CS-F300S backup disk into drive A.
- 3 Type the following to start up the program:
ADJ>ADJUST [/A : /B]*1 [/1 : /2]*2 [Enter]

• The adjustment screen appears after reading set data from the transceiver.

- 4 After the adjustment screen appears, set or modify the data as desired.

*1PLL reference crystal type.

/A: Normal crystal type. (You must select [/A] for IC-F310/F310S/F320/F320S's adjustment.)

/B: This does not activate for IC-F310/F320's adjustment.

*2RS-232C port number.

```

A:\>CD ADJ
A:\>ADJ>ADJUST [/A] [/1]
***** Trimmer Control Software for IC-F300 Series ***** Rev. 1.0
A/D VIN 177: B1h 13.88V D/A BP T1 170: AAh 2.93V
A/D TEMPS 180: B4h 27.70C D/A BP T2 188: BCh 3.16V
A/D LVIN 160: ACh 3.80V D/A BP T3 184: B8h 3.11V
A/D SD 25: 19h 0.49V D/A T4/POW 190: BEh 3.18V
D/A DTCS BL 36: 24h 14.12% D/A REF 87: 57h 1.72V
D/A SOL Lev 10: 0Ah 3.92% D/A APDev 1: 01h 0.36%
EX:155.0000MHzTX:155.0000MHzPOW: High MODE: Wide
Model: G1
Power(F1): 142 ***** BPF T1 : -70 *****
Power(L2): 88 ***** BPF T2 : -72 *****
Power(L3): 44 ***** BPF T3 : -76 *****
M O D N : 68 ***** BPF T4 : -70 *****
M O D W : 137 ***** AF VGL : 1 *****
DTCS N : 24 ***** S Q L : 10 *****
DTCS W : 51 *****
TXF SET :
    
```

← Boot up DOS, and change the directory.

← Startup command.

← Program starts up, then the adjustment screen appears after reading set data from the transceiver.

NOTE: When the EEPROM (FRONT unit; IC3) is replaced or the transceiver displays an error message and beeps, the following operation is necessary before starting the ADJUSTMENT.

1. Download the programmed data using the EX-2057 or CS-F300S from an exact same version of the transceiver, then save it. (See the instructions for detailed operation.)
2. Set the cursor to the [MODEL] and push the [↓] key on the computer keyboard.
3. Type "RESERVE" then push [Enter].
"Reserved" indicator flashes at the right hand, top corner on the computer screen.
4. Connect the transceiver which has been repaired, then write the data to the transceiver.

PROGRAM SCREEN EXAMPLE

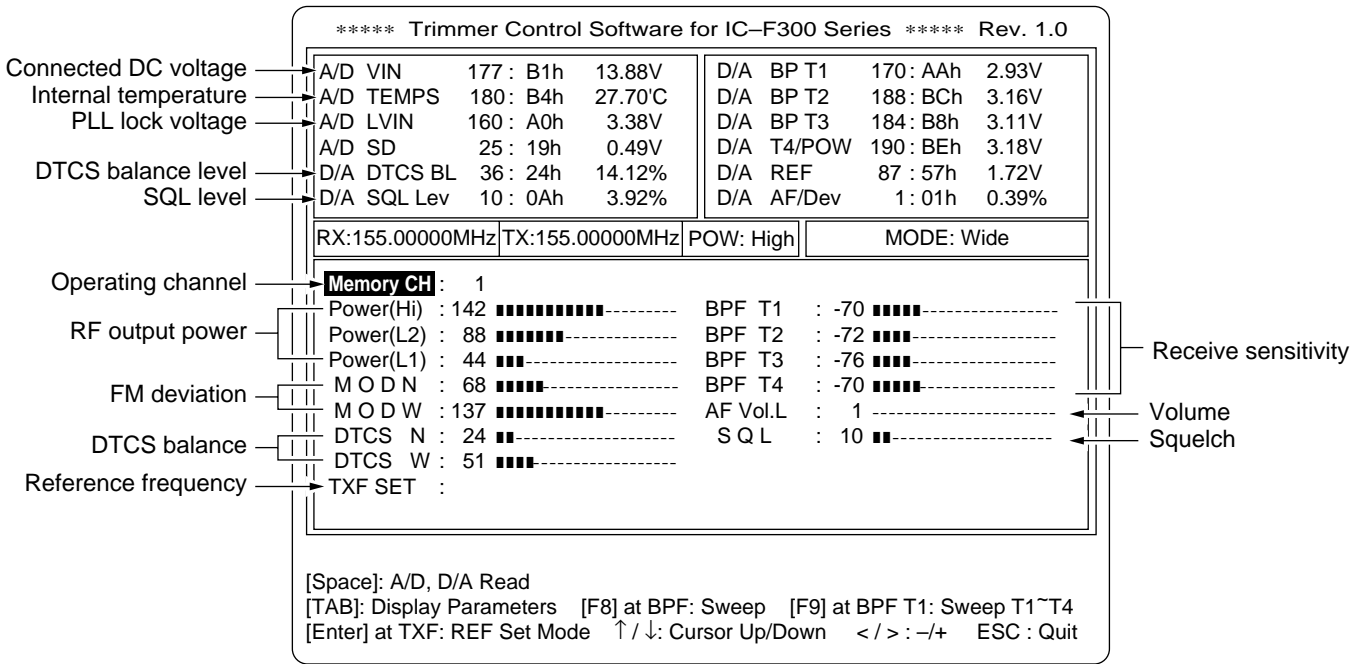

NOTE: The above values for settings are examples only. Each transceiver has its own specific values for each setting.

CONNECTIONS

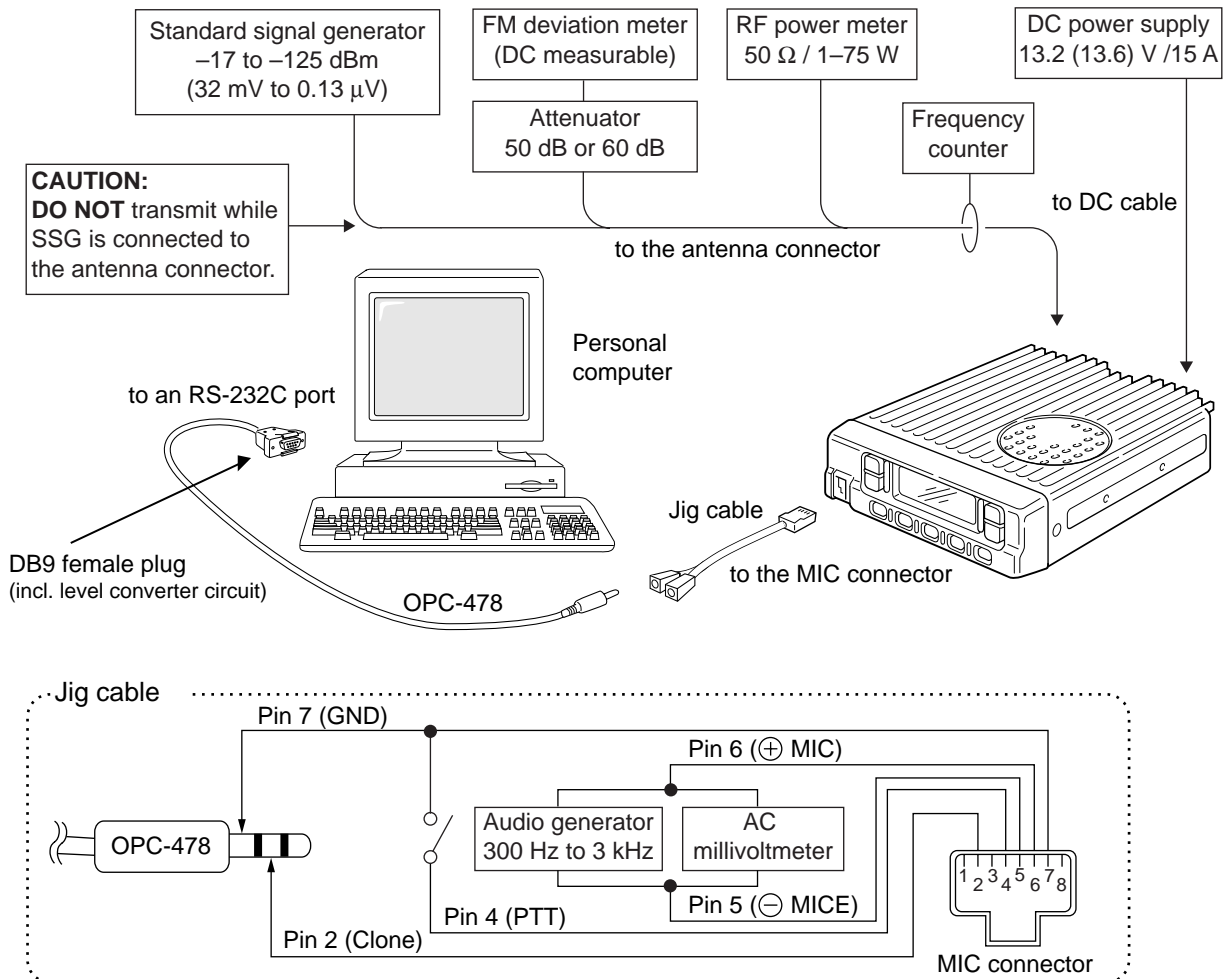

5-2 PLL ADJUSTMENT

ADJUSTMENT	ADJUSTMENT CONDITION	MEASUREMENT		VALUE	ADJUSTMENT POINT		
		UNIT	LOCATION		UNIT	ADJUST	
PLL LOCK VOLTAGE	1 • Operating frequency: (Ch 1) 155.00000 MHz [L-band] 174.00000 MHz [H-band] • Transmitting	MAIN	Connect a digital multi-meter or oscilloscope to the check point CP1.	3.5 V [L-band] 4.0 V [H-band]	MAIN	L14	
	2 • Receiving					2.6–3.6 V [L-band] 3.0–4.0 V [H-band]	Verify
	3 • Operating frequency: (Ch 2) 136.00000 MHz [L-band] 146.00000 MHz [H-band] • Transmitting					1.2–2.2 V [L-band] 0.6–1.6 V [H-band]	
	4 • Receiving					1.2–2.2 V [L-band] 0.6–1.6 V [H-band]	

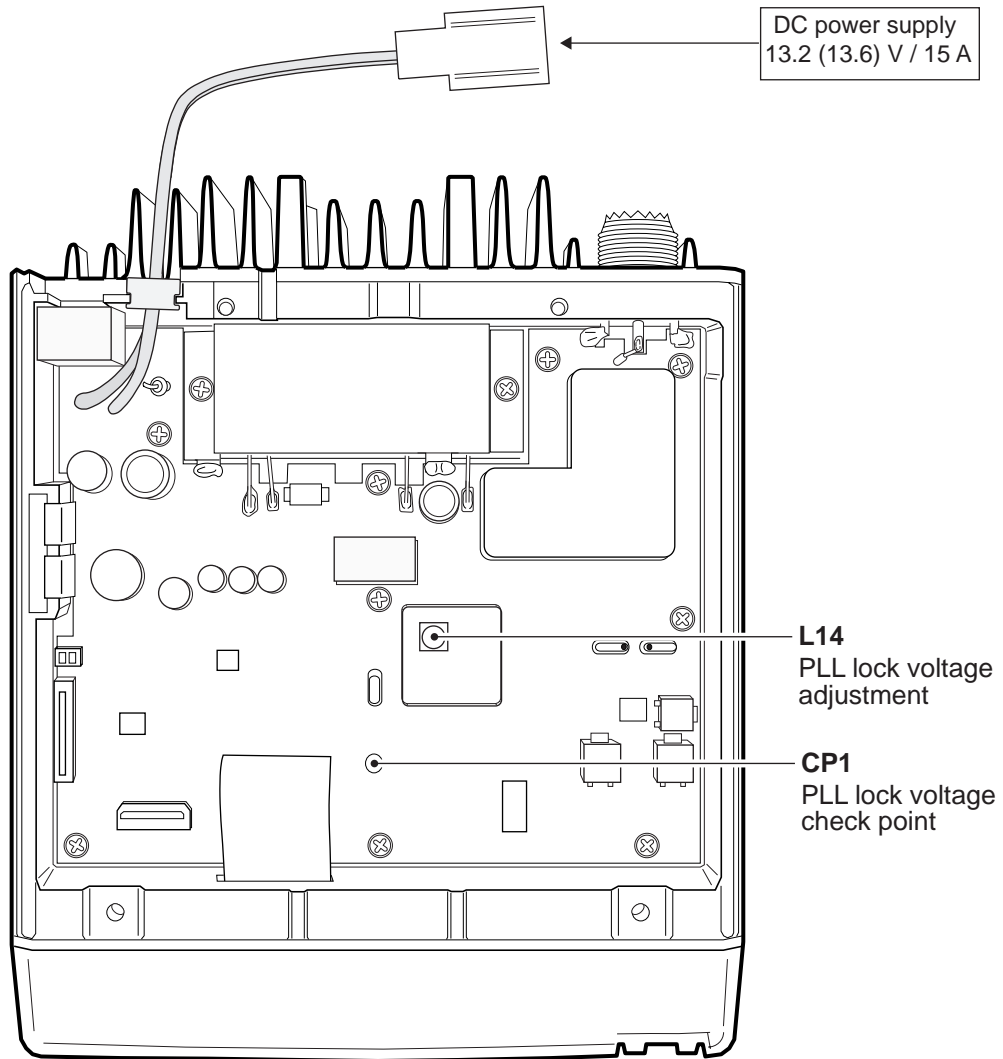

5-3 TRIMMER ADJUSTMENT

Select an operation using [↑] / [↓] keys, then set specified value using [←] / [→] keys on the connected computer keyboard.

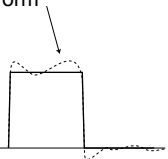
ADJUSTMENT	ADJUSTMENT CONDITION	MEASUREMENT		VALUE
		UNIT	LOCATION	
REFERENCE FREQUENCY [TXF SET]	1 • Operating frequency : (Ch 1) 155.00000 MHz [L-band] 174.00000 MHz [H-band] • Power selection: Low1 • Transmitting	Rear panel	Loosely couple a frequency counter to the antenna connector.	155.00000 MHz [L-band] 174.00000 MHz [H-band]
	2 • Transmitting			155.00155 MHz [L-band] 174.00155 MHz [H-band]
OUTPUT POWER [Power (Hi)]	1 • Operating frequency : (Ch 3) 146.00000 MHz [L-band] 160.00000 MHz [H-band] • Power selection: High • Transmitting	Rear panel	Connect an RF power meter to the antenna connector.	45.0 W [LMR] 25.0 W [PMR] 10.0 W [Italy]
	[Power (L2)] 2 • Power selection: Low2 • Transmitting			25.0 W [LMR] 10.0 W [PMR] 5.0 W [Italy]
	[Power (L1)] 3 • Power selection: Low1 • Transmitting			4.5 W [LMR] 2.5 W [PMR, Italy]
FM DEVIATION [MOD N] or [MOD W]	1 • Operating frequency : (Ch 3) 146.00000 MHz [L-band] 160.00000 MHz [H-band] • Power selection: Low1 • Connect an audio generator to the [MIC] jack and set as : 1 kHz / 40 mV • Set an FM deviation meter as: HPF : OFF LPF : 20 kHz De-emphasis : OFF Detector : (P-P)/2 • Transmitting	Rear panel	Connect an FM deviation meter to the antenna connector through an attenuator.	±4.2 kHz (Wide) ±2.1 kHz (Narrow) NOTE: [Wide/Narrow] version must adjust both setting.
DTCS WAVE FORM	1 • Operating frequency : (Ch 3) 146.00000 MHz [L-band] 160.00000 MHz [H-band] • Power selection: Low1 • No audio signal is applied to the [MIC] jack • DTCS code : 007 • Set an FM deviation meter as: HPF : OFF LPF : 20 kHz De-emphasis : OFF Detector : (P-P)/2 • Transmitting	Rear panel	Connect an FM deviation meter with an oscilloscope to the antenna connector through an attenuator.	Set to flat wave form 

TRIMMER ADJUSTMENT — continued

Select an operation using [↑] / [↓] keys, then set specified value using [←] / [→] keys on the connected computer keyboard.

ADJUSTMENT	ADJUSTMENT CONDITION	MEASUREMENT		VALUE
		UNIT	LOCATION	
RECEIVE [BPF T1]– [BPF T4]	1 <ul style="list-style-type: none"> Operating frequency: (Ch 2) 136.00000 MHz [L-band] 146.00000 MHz [H-band] Connect a standard signal generator to the antenna connector and set as: Level : 3.2 μV* (–97 dBm) Modulation: 1 kHz Deviation : \pm3.5 kHz (Wide) \pm1.75 kHz (Narrow) Receiving <p>CONVENIENT: The BPF T1–BPF T4 can be adjusted automatically.</p> <p>①-1 Set each to 0, then push the [F9] key. (The cursor must be set to the BPF T1 position.)</p> <p>①-2 The connected PC tunes BPF T1–BPF T4 to peak levels. or</p> <p>②-1 Set the cursor to one of BPF T1, T2, T3 or T4 as desired.</p> <p>②-2 Push [F8] to start tuning.</p> <p>②-3 Repeat ②-1 and ②-2 to perform additional BPF tuning.</p>	Rear panel	Connect a SINAD meter with a 4 Ω load to the external [SP] jack.	Minimum distortion level
SQUELCH LEVEL [SQL]	1 <ul style="list-style-type: none"> Operating frequency: (Ch 2) 136.00000 MHz [L-band] 146.00000 MHz [H-band] Connect an SSG to the antenna connector and set as : Level : adjust SSG's level to 8 dB SINAD on the connecting SINAD meter Modulation: OFF Receiving 	Rear panel	Connect a SINAD meter with a 4 Ω load to the external [SP] jack.	At the point where noise just appears.

*This output level of a standard signal generator (SSG) is indicated as SSG's open circuit.

5-4 BEEP ADJUSTMENT

ADJUSTMENT	ADJUSTMENT CONDITION	MEASUREMENT		VALUE	ADJUSTMENT POINT	
		UNIT	LOCATION		UNIT	ADJUST
BEEP AUDIO	1 <ul style="list-style-type: none"> Operating frequency: Any Connect an audio generator to pin 25 (MAIN unit; J2) and set as: 1 kHz / 550 mV Squelch : OPEN Volume level: 1 Receiving 	Rear panel	Connect an AC millivoltmeter with 4 Ω load to the [SP] jack.	62.5 mV	FRONT	R60

• MAIN unit

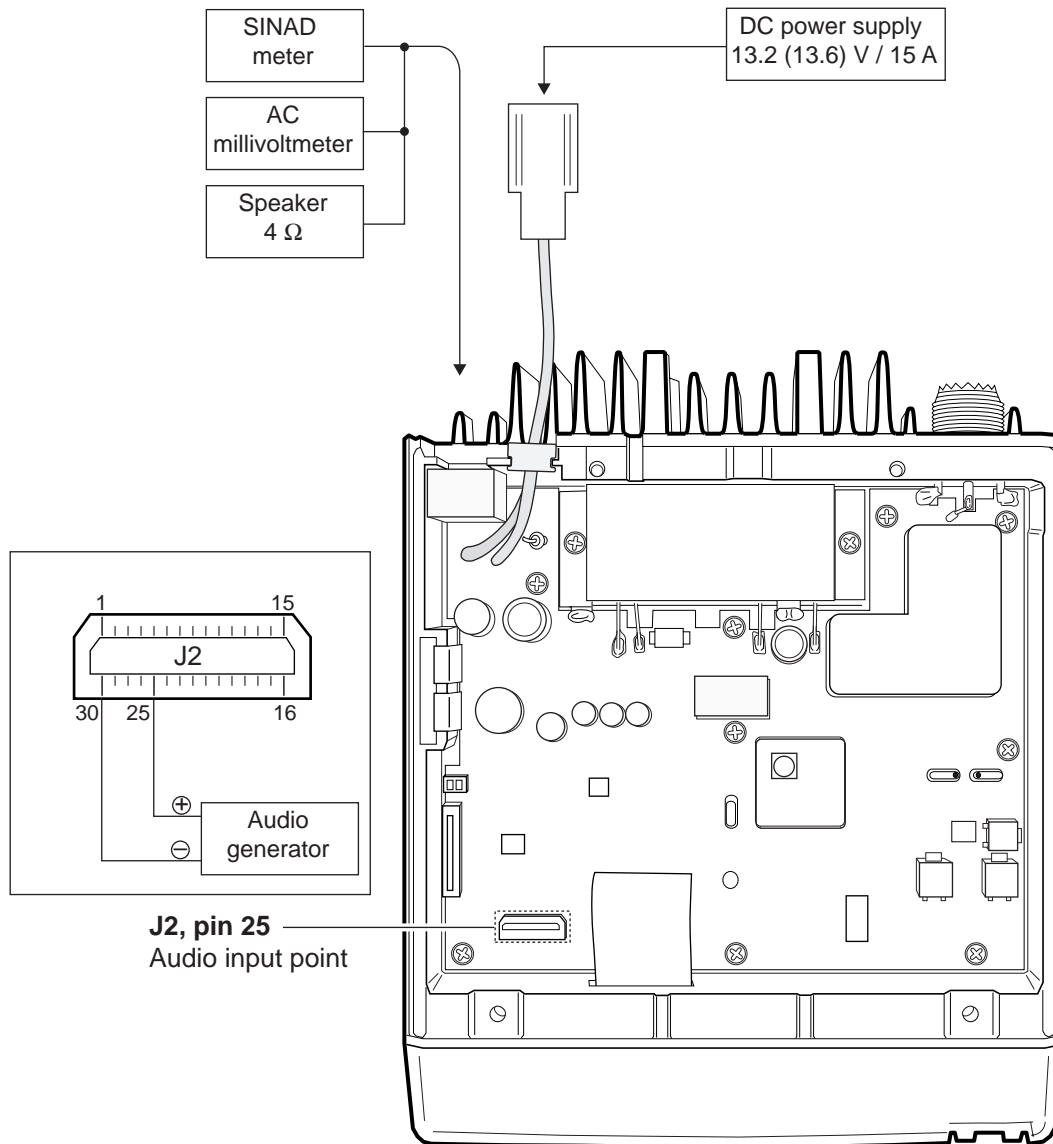

• FRONT unit

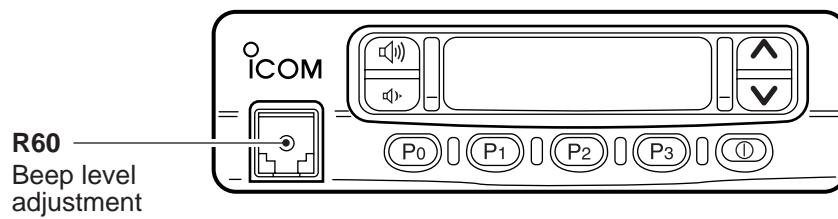

SECTION 6 PARTS LIST

[FRONT UNIT]

REF NO.	ORDER NO.	DESCRIPTION	
IC1	1140007911	S.IC	HD6433875B20H
IC2	1110003500	S.IC	S-80742SL-A6-T1
IC3	1130008670	S.IC	25LC160T-I/SN
Q1	1530002060	S.TRANSISTOR	2SC4081 T107 R
Q3	1590000440	S.TRANSISTOR	DTA143ZUA T106
	1530002060	S.TRANSISTOR	2SC4081 T107 R
Q4	1590000660	S.TRANSISTOR	DTC144TU T107
Q5	1590001650	S.TRANSISTOR	XP4601 (TX)
Q6	1530002060	S.TRANSISTOR	2SC4081 T107 R
Q7	1530002060	S.TRANSISTOR	2SC4081 T107 R
Q10	1590000660	S.TRANSISTOR	DTC144TU T107
Q11	1530002060	S.TRANSISTOR	2SC4081 T107 R
Q12	1530002060	S.TRANSISTOR	2SC4081 T107 R
Q13	1530002060	S.TRANSISTOR	2SC4081 T107 R
Q14	1530002060	S.TRANSISTOR	2SC4081 T107 R
Q15	1530002060	S.TRANSISTOR	2SC4081 T107 R
Q16	1530002060	S.TRANSISTOR	2SC4081 T107 R
Q17	1530002060	S.TRANSISTOR	2SC4081 T107 R
Q18	1590000430	S.TRANSISTOR	DTC144EUA T106
Q19	1590000430	S.TRANSISTOR	DTC144EUA T106
D1	1790001280	S.DIODE	MA111 (TX)
D2	1750000130	S.DIODE	DA204U T107
D3	1750000130	S.DIODE	DA204U T107
D4	1750000130	S.DIODE	DA204U T107
D5	1790000620	S.DIODE	MA77 (TX)
D6	1730002320	S.ZENER	MA8051-M (TX)
X1	6050010150	S.XTAL	CR-590 (6.8015 MHz)
L1	6200001720	S.COIL	NL 322522T-1R0J
L3	6200003190	S.COIL	NL 322522T-470J
R1	7030003560	S.RESISTOR	ERJ3GEYJ 103 V (10 kΩ)
R2	7030003680	S.RESISTOR	ERJ3GEYJ 104 V (100 kΩ)
R3	7030003720	S.RESISTOR	ERJ3GEYJ 224 V (220 kΩ)
R4	7030003680	S.RESISTOR	ERJ3GEYJ 104 V (100 kΩ)
R5	7030003570	S.RESISTOR	ERJ3GEYJ 123 V (12 kΩ)
R6	7030003570	S.RESISTOR	ERJ3GEYJ 123 V (12 kΩ)
R7	7030003800	S.RESISTOR	ERJ3GEYJ 105 V (1 MΩ)
R8	7030003200	S.RESISTOR	ERJ3GEYJ 100 V (10 Ω)
R11	7030003430	S.RESISTOR	ERJ3GEYJ 821 V (820 Ω)
R12	7030003390	S.RESISTOR	ERJ3GEYJ 391 V (390 Ω)
R14	7030003390	S.RESISTOR	ERJ3GEYJ 391 V (390 Ω)
R15	7030003480	S.RESISTOR	ERJ3GEYJ 222 V (2.2 kΩ)
R16	7030003480	S.RESISTOR	ERJ3GEYJ 222 V (2.2 kΩ)
R17	7410000950	S.ARRAY	EXB-V8V 102JV
R18	7030003400	S.RESISTOR	ERJ3GEYJ 471 V (470 Ω)
R19	7030003400	S.RESISTOR	ERJ3GEYJ 471 V (470 Ω)
R20	7030003440	S.RESISTOR	ERJ3GEYJ 102 V (1 kΩ)
R21	7030003440	S.RESISTOR	ERJ3GEYJ 102 V (1 kΩ)
R22	7030003200	S.RESISTOR	ERJ3GEYJ 100 V (10 Ω)
R24	7030003710	S.RESISTOR	ERJ3GEYJ 184 V (180 kΩ)
R25	7030003650	S.RESISTOR	ERJ3GEYJ 563 V (56 kΩ)
R26	7030003510	S.RESISTOR	ERJ3GEYJ 392 V (3.9 kΩ)
R27	7030003630	S.RESISTOR	ERJ3GEYJ 393 V (39 kΩ)
R28	7030003440	S.RESISTOR	ERJ3GEYJ 102 V (1 kΩ)
R29	7030003440	S.RESISTOR	ERJ3GEYJ 102 V (1 kΩ)
R30	7030003560	S.RESISTOR	ERJ3GEYJ 103 V (10 kΩ)
R31	7030003560	S.RESISTOR	ERJ3GEYJ 103 V (10 kΩ)
R32	7030003600	S.RESISTOR	ERJ3GEYJ 223 V (22 kΩ)
R33	7030003660	S.RESISTOR	ERJ3GEYJ 683 V (68 kΩ)
R34	7030003610	S.RESISTOR	ERJ3GEYJ 273 V (27 kΩ)
R35	7030003560	S.RESISTOR	ERJ3GEYJ 103 V (10 kΩ)
R36	7030003570	S.RESISTOR	ERJ3GEYJ 123 V (12 kΩ)
R37	7030003570	S.RESISTOR	ERJ3GEYJ 123 V (12 kΩ)

[FRONT UNIT]

REF NO.	ORDER NO.	DESCRIPTION	
R38	7030003640	S.RESISTOR	ERJ3GEYJ 473 V (47 kΩ)
R39	7030003680	S.RESISTOR	ERJ3GEYJ 104 V (100 kΩ)
R40	7030003680	S.RESISTOR	ERJ3GEYJ 104 V (100 kΩ)
R41	7030003730	S.RESISTOR	ERJ3GEYJ 274 V (270 kΩ)
R42	7030003740	S.RESISTOR	ERJ3GEYJ 334 V (330 kΩ)
R43	7030003570	S.RESISTOR	ERJ3GEYJ 123 V (12 kΩ)
R44	7410000950	S.ARRAY	EXB-V8V 102JV
R45	7410000950	S.ARRAY	EXB-V8V 102JV
R46	7410000950	S.ARRAY	EXB-V8V 102JV
R47	7410000950	S.ARRAY	EXB-V8V 102JV
R48	7410000950	S.ARRAY	EXB-V8V 102JV
R49	7030003320	S.RESISTOR	ERJ3GEYJ 101 V (100 Ω)
R50	7030003680	S.RESISTOR	ERJ3GEYJ 104 V (100 kΩ)
R51	7030003440	S.RESISTOR	ERJ3GEYJ 102 V (1 kΩ)
R52	7030003440	S.RESISTOR	ERJ3GEYJ 102 V (1 kΩ)
R53	7030003440	S.RESISTOR	ERJ3GEYJ 102 V (1 kΩ)
R54	7030003440	S.RESISTOR	ERJ3GEYJ 102 V (1 kΩ)
R55	7030003680	S.RESISTOR	ERJ3GEYJ 104 V (100 kΩ)
R56	7030003530	S.RESISTOR	ERJ3GEYJ 562 V (5.6 kΩ)
R57	7030003580	S.RESISTOR	ERJ3GEYJ 153 V (15 kΩ)
R58	7030003640	S.RESISTOR	ERJ3GEYJ 473 V (47 kΩ)
R59	7030003440	S.RESISTOR	ERJ3GEYJ 102 V (1 kΩ)
R60	7310002740	S.TRIMMER	RV-150 (RH03A3A14X0FC)103
R61	7030003680	S.RESISTOR	ERJ3GEYJ 104 V (100 kΩ)
R62	7030003440	S.RESISTOR	ERJ3GEYJ 102 V (1 kΩ)
R63	7030003440	S.RESISTOR	ERJ3GEYJ 102 V (1 kΩ)
R64	7030003440	S.RESISTOR	ERJ3GEYJ 102 V (1 kΩ)
R65	7030003680	S.RESISTOR	ERJ3GEYJ 104 V (100 kΩ)
R66	7030003680	S.RESISTOR	ERJ3GEYJ 104 V (100 kΩ)
R67	7030003680	S.RESISTOR	ERJ3GEYJ 104 V (100 kΩ)
R68	7030003640	S.RESISTOR	ERJ3GEYJ 473 V (47 kΩ)
R69	7030003680	S.RESISTOR	ERJ3GEYJ 104 V (100 kΩ)
R70	7030003640	S.RESISTOR	ERJ3GEYJ 473 V (47 kΩ)
R71	7030003440	S.RESISTOR	ERJ3GEYJ 102 V (1 kΩ)
R72	7030003400	S.RESISTOR	ERJ3GEYJ 471 V (470 Ω)
R73	7030003470	S.RESISTOR	ERJ3GEYJ 182 V (1.8 kΩ)
R74	7030003470	S.RESISTOR	ERJ3GEYJ 182 V (1.8 kΩ)
R75	7030003470	S.RESISTOR	ERJ3GEYJ 182 V (1.8 kΩ)
R76	7030003470	S.RESISTOR	ERJ3GEYJ 182 V (1.8 kΩ)
R77	7030003470	S.RESISTOR	ERJ3GEYJ 182 V (1.8 kΩ)
R78	7030003650	S.RESISTOR	ERJ3GEYJ 563 V (56 kΩ)
R79	7030003630	S.RESISTOR	ERJ3GEYJ 393 V (39 kΩ)
R80	7030003680	S.RESISTOR	ERJ3GEYJ 104 V (100 kΩ)
R81	7030003680	S.RESISTOR	ERJ3GEYJ 104 V (100 kΩ)
R82	7030003680	S.RESISTOR	ERJ3GEYJ 104 V (100 kΩ)
R83	7030003680	S.RESISTOR	ERJ3GEYJ 104 V (100 kΩ)
R84	7030003680	S.RESISTOR	ERJ3GEYJ 104 V (100 kΩ)
R85	7030003440	S.RESISTOR	ERJ3GEYJ 102 V (1 kΩ)
R86	7030003440	S.RESISTOR	ERJ3GEYJ 102 V (1 kΩ)
R87	7030003430	S.RESISTOR	ERJ3GEYJ 821 V (820 Ω)

©: LCD type (F310/F320), Ⓔ: LED type (F310S/F320S)

S.=Surface mount

[FRONT UNIT]

REF NO.	ORDER NO.	DESCRIPTION	
C1	4030006900	S.CERAMIC	C1608 JB 1E 103K-T-A
C2	4030006900	S.CERAMIC	C1608 JB 1E 103K-T-A
C3	4030006900	S.CERAMIC	C1608 JB 1E 103K-T-A
C4	4030006900	S.CERAMIC	C1608 JB 1E 103K-T-A
C5	4030006900	S.CERAMIC	C1608 JB 1E 103K-T-A
C6	4030006900	S.CERAMIC	C1608 JB 1E 103K-T-A
C7	4030006900	S.CERAMIC	C1608 JB 1E 103K-T-A
C8	4030006900	S.CERAMIC	C1608 JB 1E 103K-T-A
C9	4550006200	S.TANTALUM	ECST0JY106R
C10	4030006900	S.CERAMIC	C1608 JB 1E 103K-T-A
C11	4030006860	S.CERAMIC	C1608 JB 1H 102K-T-A
C12	4030006900	S.CERAMIC	C1608 JB 1E 103K-T-A
C13	4030006860	S.CERAMIC	C1608 JB 1H 102K-T-A
C14	4550006140	S.TANTALUM	ECST1EY474R
C15	4030006860	S.CERAMIC	C1608 JB 1H 102K-T-A
C16	4030006860	S.CERAMIC	C1608 JB 1H 102K-T-A
C17	4030006860	S.CERAMIC	C1608 JB 1H 102K-T-A
C18	4030007090	S.CERAMIC	C1608 CH 1H 470J-T-A
C19	4030009920	S.CERAMIC	C1608 CH 1H 050B-T-A
C20	4030009990	S.CERAMIC	C1608 CH 1H 200J-T-A
C21	4030006900	S.CERAMIC	C1608 JB 1E 103K-T-A
C22	4030007090	S.CERAMIC	C1608 CH 1H 470J-T-A
C23	4030007090	S.CERAMIC	C1608 CH 1H 470J-T-A
C24	4030007090	S.CERAMIC	C1608 CH 1H 470J-T-A
C25	4030007090	S.CERAMIC	C1608 CH 1H 470J-T-A
C26	4030007090	S.CERAMIC	C1608 CH 1H 470J-T-A
C27	4030007090	S.CERAMIC	C1608 CH 1H 470J-T-A
C28	4030006860	S.CERAMIC	C1608 JB 1H 102K-T-A
C29	4030006860	S.CERAMIC	C1608 JB 1H 102K-T-A
C30	4030006850	S.CERAMIC	C1608 JB 1H 471K-T-A
C32	4030006860	S.CERAMIC	C1608 JB 1H 102K-T-A
C33	4030006860	S.CERAMIC	C1608 JB 1H 102K-T-A
C34	4030007090	S.CERAMIC	C1608 CH 1H 470J-T-A
C35	4030006860	S.CERAMIC	C1608 JB 1H 102K-T-A
C36	4030006900	S.CERAMIC	C1608 JB 1E 103K-T-A
C37	4550006700	S.TANTALUM	ECST1AY106R
C38	4030008880	S.CERAMIC	C1608 JB 1C 223K-T-A
C39	4030011600	S.CERAMIC	C1608 JB 1C 104KT-N
C40	4030008920	S.CERAMIC	C1608 JB 1C 473K-T-A
C41	4030008900	S.CERAMIC	C1608 JB 1C 333K-T-A
C42	4030011600	S.CERAMIC	C1608 JB 1C 104KT-N
C43	4030006900	S.CERAMIC	C1608 JB 1E 103K-T-A
C44	4030006900	S.CERAMIC	C1608 JB 1E 103K-T-A
C45	4030006900	S.CERAMIC	C1608 JB 1E 103K-T-A
C46	4030007090	S.CERAMIC	C1608 CH 1H 470J-T-A
C47	4030007090	S.CERAMIC	C1608 CH 1H 470J-T-A
C48	4030007090	S.CERAMIC	C1608 CH 1H 470J-T-A
C49	4030007090	S.CERAMIC	C1608 CH 1H 470J-T-A
C50	4030007090	S.CERAMIC	C1608 CH 1H 470J-T-A
C52	4030007090	S.CERAMIC	C1608 CH 1H 470J-T-A
C56	4030007090	S.CERAMIC	C1608 CH 1H 470J-T-A
C57	4030007090	S.CERAMIC	C1608 CH 1H 470J-T-A
C58	4030007090	S.CERAMIC	C1608 CH 1H 470J-T-A
C59	4030007090	S.CERAMIC	C1608 CH 1H 470J-T-A
C60	4030007090	S.CERAMIC	C1608 CH 1H 470J-T-A
C61	4030007090	S.CERAMIC	C1608 CH 1H 470J-T-A
C62	4030007090	S.CERAMIC	C1608 CH 1H 470J-T-A
C63	4030007090	S.CERAMIC	C1608 CH 1H 470J-T-A
C64	4030007090	S.CERAMIC	C1608 CH 1H 470J-T-A
C65	4030007090	S.CERAMIC	C1608 CH 1H 470J-T-A
C66	4030007090	S.CERAMIC	C1608 CH 1H 470J-T-A
C67	4030006860	S.CERAMIC	C1608 JB 1H 102K-T-A
C69	4030006860	S.CERAMIC	C1608 JB 1H 102K-T-A
C70	4030007090	S.CERAMIC	C1608 CH 1H 470J-T-A
C71	4030007090	S.CERAMIC	C1608 CH 1H 470J-T-A
C73	4030007090	S.CERAMIC	C1608 CH 1H 470J-T-A
C74	4030007090	S.CERAMIC	C1608 CH 1H 470J-T-A
C77	4030007090	S.CERAMIC	C1608 CH 1H 470J-T-A
C78	4030007090	S.CERAMIC	C1608 CH 1H 470J-T-A
C79	4030007090	S.CERAMIC	C1608 CH 1H 470J-T-A
C80	4030007090	S.CERAMIC	C1608 CH 1H 470J-T-A
C82	4030011600	S.CERAMIC	C1608 JB 1C 104KT-N
C83	4030006860	S.CERAMIC	C1608 JB 1H 102K-T-A (E) only
C84	4030006860	S.CERAMIC	C1608 JB 1H 102K-T-A (E) only
C85	4030006860	S.CERAMIC	C1608 JB 1H 102K-T-A (E) only
C86	4030006860	S.CERAMIC	C1608 JB 1H 102K-T-A (E) only
C87	4030006860	S.CERAMIC	C1608 JB 1H 102K-T-A (E) only
C88	4030006860	S.CERAMIC	C1608 JB 1H 102K-T-A (E) only
C89	4030006860	S.CERAMIC	C1608 JB 1H 102K-T-A (E) only
C90	4030006860	S.CERAMIC	C1608 JB 1H 102K-T-A (E) only
C92	4030007090	S.CERAMIC	C1608 CH 1H 470J-T-A (E) only

[FRONT UNIT]

REF NO.	ORDER NO.	DESCRIPTION		
J1	6450001470	CONNECTOR	95003-2881	
J2	6510020510	S.CONNECTOR	FH12-40S-0.5SV	
DS1	5030001540	LCD	LD-HU10140J	(C) only
DS2	5040002310	S.LED	SML-311YTT86	(C) only
DS3	5040002310	S.LED	SML-311YTT86	(C) only
DS4	5040002310	S.LED	SML-311YTT86	(C) only
DS5	5040002310	S.LED	SML-311YTT86	(C) only
DS6	5040002310	S.LED	SML-311YTT86	(C) only
DS7	5040002310	S.LED	SML-311YTT86	(C) only
DS8	5040002310	S.LED	SML-311YTT86	
DS9	5040002310	S.LED	SML-311YTT86	
DS10	5040002310	S.LED	SML-311YTT86	
DS11	5040002310	S.LED	SML-311YTT86	
DS12	5040001760	S.LED	SEC 2422C	(E) only
DS13	5040002310	S.LED	SML-311YTT86	(C) only
DS14	5040002310	S.LED	SML-311YTT86	(C) only
DS15	5040002310	S.LED	SML-311YTT86	(C) only
DS16	5040002310	S.LED	SML-311YTT86	(C) only
DS17	5040002310	S.LED	SML-311YTT86	(C) only
W1	7030000010	S.JUMPER	MCR10EZJH JPW (000)	
W2	7030003860	S.JUMPER	ERJ3GE JPW V	
W3	8900007680	CABLE	OPC-741	
EP1	0910049322	PCB	B 5042B	(C)
	0910051231	PCB	B 5289A	(E)
EP2	8930044930	LCD CONTACT	SRCN-2055-SP-N-W	(C) only

(C): LCD type (F310/F320), (E): LED type (F310S/F320S)

S.=Surface mount

[MAIN UNIT]

REF NO.	ORDER NO.	DESCRIPTION	
IC1	1150001930	IC	SC-1364 [P] [L-band]
	1150001940	IC	SC-1365 [P] [H-band]
	1150001760	IC	M68702L [L] [L-band]
	1150001750	IC	M68702H [L] [H-band]
IC2	1130007610	S.IC	μPD3140GS-E1 (DS8)
IC3	1110003490	S.IC	TA31136FN (D, EL)
IC4	1130008090	S.IC	BU4066BCFV-E1
IC5	1190000350	S.IC	M62363FP-650C
IC6	1110003780	S.IC	NJM2902V-TE1
IC7	1110003780	S.IC	NJM2902V-TE1
IC8	1110003800	S.IC	NJM2904V-TE1
IC9	1180001080	S.IC	S-81250PG-PD-T1
IC10	1110003090	IC	LA4425A
IC11	1130007510	S.IC	BU4094BCFV-E1
Q1	1530003291	S.TRANSISTOR	2SC4703-T1 SE
Q2	1530002600	S.TRANSISTOR	2SC4215-O (TE85R)
Q3	1530002600	S.TRANSISTOR	2SC4215-O (TE85R)
Q4	1530002600	S.TRANSISTOR	2SC4215-O (TE85R)
Q5	1530002600	S.TRANSISTOR	2SC4215-O (TE85R)
Q6	1530002600	S.TRANSISTOR	2SC4215-O (TE85R)
Q7	1530002920	S.TRANSISTOR	2SC4226-T2 R25
Q8	1530002920	S.TRANSISTOR	2SC4226-T2 R25
Q9	1590000430	S.TRANSISTOR	DTC144EUA T106
Q10	1530002060	S.TRANSISTOR	2SC4081 T107 R
Q11	1560000540	S.FET	2SK880-Y (TE85R)
Q12	1580000610	S.FET	3SK239XR-TL
Q13	1580000490	S.FET	3SK166A-2-T7
Q14	1530002360	S.TRANSISTOR	2SC2714-Y (TE85R)
Q15	1530002060	S.TRANSISTOR	2SC4081 T107 R
Q16	1590000720	S.TRANSISTOR	DTA144EUA T106
Q17	1520000380	TRANSISTOR	2SB1143 S
Q18	1530002060	S.TRANSISTOR	2SC4081 T107 R
Q19	1590000430	S.TRANSISTOR	DTC144EUA T106
Q20	1590000990	S.TRANSISTOR	DTC363EK T147
Q21	1590000430	S.TRANSISTOR	DTC144EUA T106
Q22	1590000430	S.TRANSISTOR	DTC144EUA T106
Q23	1590000430	S.TRANSISTOR	DTC144EUA T106
Q24	1590000430	S.TRANSISTOR	DTC144EUA T106
Q25	1590000680	S.TRANSISTOR	DTC114EUA T106
Q26	1520000580	S.TRANSISTOR	2SB1124S-TD
Q27	1510000670	S.TRANSISTOR	2SA1588-GR (TE85R)
Q28	1510000670	S.TRANSISTOR	2SA1588-GR (TE85R)
Q29	1520000650	S.TRANSISTOR	2SB1201-S-TL
Q30	1590001190	S.TRANSISTOR	XP6501-(TX) .AB
Q31	1590000430	S.TRANSISTOR	DTC144EUA T106
Q32	1590000680	S.TRANSISTOR	DTC114EUA T106
Q33	1590000680	S.TRANSISTOR	DTC114EUA T106
Q34	1590001390	S.FET	2SJ144-Y (TE85R)
Q35	1590000720	S.TRANSISTOR	DTA144EUA T106
Q36	1540000550	S.TRANSISTOR	2SD1664 T100Q
Q37	1590001030	S.TRANSISTOR	DTC144WU T107
Q38	1540000550	S.TRANSISTOR	2SD1664 T100Q
Q39	1590000430	S.TRANSISTOR	DTC144EUA T106
Q40	1530002060	S.TRANSISTOR	2SC4081 T107 R [L] only
D1	1790001210	S.DIODE	1SS375-TL
D2	1790001210	S.DIODE	1SS375-TL
D3	1710000310	DIODE	MI407
D5	1790000620	S.DIODE	MA77 (TX)
D6	1790000620	S.DIODE	MA77 (TX)
D7	1720000370	S.VARICAP	HVU350TRF
D8	1720000370	S.VARICAP	HVU350TRF
D9	1790000620	S.DIODE	MA77 (TX)
D10	1790000620	S.DIODE	MA77 (TX)
D11	1790001280	S.DIODE	MA111 (TX)
D12	1720000670	S.VARICAP	HVU17TRF
D13	1710000730	S.DIODE	MI809-T11
D14	1710000730	S.DIODE	MI809-T11
D15	1750000260	S.DIODE	1SS352 (TPH3)
D16	1720000370	S.VARICAP	HVU350TRF
D17	1720000370	S.VARICAP	HVU350TRF
D18	1720000370	S.VARICAP	HVU350TRF
D19	1720000370	S.VARICAP	HVU350TRF
D20	1720000370	S.VARICAP	HVU350TRF
D21	1720000370	S.VARICAP	HVU350TRF
D22	1160000060	S.DIODE	DAN202U T107
D23	1160000060	S.DIODE	DAN202U T107
D24	1790001280	S.DIODE	MA111 (TX)

[MAIN UNIT]

REF NO.	ORDER NO.	DESCRIPTION	
D25	1790001280	S.DIODE	MA111 (TX)
D26	1160000060	S.DIODE	DAN202U T107
D27	1790000700	DIODE	DSA3A1
D28	1790001280	S.DIODE	MA111 (TX)
D29	1750000370	S.DIODE	DA221 TL
D30	1730002300	S.ZENER	MA8082-M (TX)
D31	1750000130	S.DIODE	DA204U T107
D32	1730000520	ZENER	RD20E B2
D33	1160000060	S.DIODE	DAN202U T107
F11	2010002210	XTAL	FL-285 (31.050 MHz)
F13	2020001080	S.CERAMIC	SFPC450G-TC01
F14	2020001490	S.CERAMIC	SFPC450E-TC01
X1	6050009980	XTAL	CR-575 (15.3 MHz)
X3	6070000210	S.DISCRIMINATOR	CDBCA450CX24
L1	6110001670	COIL	LA-253
L2	6110001600	COIL	LA-243
L3	6110001670	COIL	LA-253
L4	6170000230	COIL	LW-25
L5	6110001670	COIL	LA-253
L6	6200001640	S.COIL	ELJNC 10NK-F [L] [L-band]
	6200001770	S.COIL	ELJNC 47NK-F other
L7	6200001640	S.COIL	ELJNC 10NK-F [L] [L-band]
	6200001770	S.COIL	ELJNC 47NK-F other
L8	6200003670	S.COIL	ELJNC 68NK-F [P]
	6200001770	S.COIL	ELJNC 47NK-F [L]
L9	6200003290	S.COIL	ELJNC R12K-F [P] [L-band]
	6200001920	S.COIL	ELJNC R15K-F [P] [H-band]
	6200001630	S.COIL	ELJNC R10K-F [L]
L11	6200006980	S.COIL	ELJRE R10G-F
L12	6200006980	S.COIL	ELJRE R10G-F
L13	6200006980	S.COIL	ELJRE R10G-F
L14	6200004850	S.COIL	MC152-E558CN-100024
L15	6200003090	S.COIL	NL 322522T-2R7J-3
L16	6200007000	S.COIL	ELJRE 82NG-F
L17	6200003850	S.COIL	36CS-656LZ-09K=P3
L18	6200003850	S.COIL	36CS-656LZ-09K=P3
L19	6200007160	S.COIL	LQN1H 54NK04
L20	6200007160	S.COIL	LQN1H 54NK04
L21	6200002360	S.COIL	LQN 1A 33NJ04
L22	6200002360	S.COIL	LQN 1A 33NJ04
L23	6200005740	S.COIL	ELJRE 47NG-F
L24	6200006980	S.COIL	ELJRE R10G-F
L25	6200004790	S.COIL	MLF1608D R47K-T
L26	6200003960	S.COIL	MLF1608A 1R0K-T
L27	6200003960	S.COIL	MLF1608A 1R0K-T
R1	7030000610	S.RESISTOR	MCR10EZHZJ 82 kΩ
R2	7030003280	S.RESISTOR	ERJ3GEYJ 470 V (47 Ω)
R3	7030003280	S.RESISTOR	ERJ3GEYJ 470 V (47 Ω)
R4	7030003440	S.RESISTOR	ERJ3GEYJ 102 V (1 kΩ) [P]
	7030003380	S.RESISTOR	ERJ3GEYJ 331 V (330 Ω) [L] [L-band]
	7030003320	S.RESISTOR	ERJ3GEYJ 101 V (100 Ω) [L] [H-band]
R5	7030003460	S.RESISTOR	ERJ3GEYJ 152 V (1.5 kΩ) [P]
	7030003470	S.RESISTOR	ERJ3GEYJ 182 V (1.8 kΩ) [L]
R6	7030000950	S.RESISTOR	MCR18EZHZJ 22 Ω (220)
R7	7030000960	S.RESISTOR	MCR18EZHZJ 33 Ω (330)
R8	7030000310	S.RESISTOR	MCR10EZHZJ 270 Ω (271) [P] only
R9	7030001100	S.RESISTOR	MCR50JZHZJ 56 Ω (560)
R10	7030000190	S.RESISTOR	MCR10EZHZJ 27 Ω (270) [P]
	7030000110	S.RESISTOR	MCR10EZHZJ 5.6 Ω (5R6) [L]
R11	7030000190	S.RESISTOR	MCR10EZHZJ 27 Ω (270) [P]
	7030000110	S.RESISTOR	MCR10EZHZJ 5.6 Ω (5R6) [L]
R12	7030003410	S.RESISTOR	ERJ3GEYJ 561 V (560 Ω)
R13	7030003480	S.RESISTOR	ERJ3GEYJ 222 V (2.2 kΩ)
R14	7030003240	S.RESISTOR	ERJ3GEYJ 220 V (22 Ω)
R15	7030003320	S.RESISTOR	ERJ3GEYJ 101 V (100 Ω)
R16	7030003510	S.RESISTOR	ERJ3GEYJ 392 V (3.9 kΩ) [P]
	7030003550	S.RESISTOR	ERJ3GEYJ 822 V (8.2 kΩ) [L] [L-band]
	7030003530	S.RESISTOR	ERJ3GEYJ 562 V (5.6 kΩ) [L] [H-band]

[P]: PMR (F310/F310S), [L]: LMR (F320/F320S)

S.=Surface mount

[MAIN UNIT]

REF NO.	ORDER NO.	DESCRIPTION	
R17	7030003470	S.RESISTOR	ERJ3GEYJ 182 V (1.8 kΩ)
R18	7030003320	S.RESISTOR	ERJ3GEYJ 101 V (100 Ω)
R19	7030003340	S.RESISTOR	ERJ3GEYJ 151 V (150 Ω)
R20	7030003550	S.RESISTOR	ERJ3GEYJ 822 V (8.2 kΩ) [P]
	7030003580	S.RESISTOR	ERJ3GEYJ 153 V (15 kΩ) [L]
R21	7030003530	S.RESISTOR	ERJ3GEYJ 562 V (5.6 kΩ)
R22	7030003320	S.RESISTOR	ERJ3GEYJ 101 V (100 Ω)
R23	7030003520	S.RESISTOR	ERJ3GEYJ 472 V (4.7 kΩ)
R24	7030003320	S.RESISTOR	ERJ3GEYJ 101 V (100 Ω)
R25	7030003520	S.RESISTOR	ERJ3GEYJ 472 V (4.7 kΩ)
R26	7030003390	S.RESISTOR	ERJ3GEYJ 391 V (390 Ω)
R27	7030003630	S.RESISTOR	ERJ3GEYJ 393 V (39 kΩ)
R28	7030003400	S.RESISTOR	ERJ3GEYJ 471 V (470 Ω)
R29	7030003660	S.RESISTOR	ERJ3GEYJ 683 V (68 kΩ)
R30	7030003420	S.RESISTOR	ERJ3GEYJ 681 V (680 Ω)
R31	7030003660	S.RESISTOR	ERJ3GEYJ 683 V (68 kΩ)
R32	7030003320	S.RESISTOR	ERJ3GEYJ 101 V (100 Ω)
R33	7030003400	S.RESISTOR	ERJ3GEYJ 471 V (470 Ω)
R34	7030003550	S.RESISTOR	ERJ3GEYJ 822 V (8.2 kΩ)
R35	7030003360	S.RESISTOR	ERJ3GEYJ 221 V (220 Ω)
R36	7030003550	S.RESISTOR	ERJ3GEYJ 822 V (8.2 kΩ)
R37	7030003440	S.RESISTOR	ERJ3GEYJ 102 V (1 kΩ)
R38	7030003440	S.RESISTOR	ERJ3GEYJ 102 V (1 kΩ)
R39	7030003640	S.RESISTOR	ERJ3GEYJ 473 V (47 kΩ)
R40	7030003520	S.RESISTOR	ERJ3GEYJ 472 V (4.7 kΩ)
R41	7030003440	S.RESISTOR	ERJ3GEYJ 102 V (1 kΩ)
R42	7030003410	S.RESISTOR	ERJ3GEYJ 561 V (560 Ω)
R43	7030003480	S.RESISTOR	ERJ3GEYJ 222 V (2.2 kΩ)
R44	7030003200	S.RESISTOR	ERJ3GEYJ 100 V (10 Ω)
R45	7030003480	S.RESISTOR	ERJ3GEYJ 222 V (2.2 kΩ)
R46	7030003560	S.RESISTOR	ERJ3GEYJ 103 V (10 kΩ)
R47	7030003440	S.RESISTOR	ERJ3GEYJ 102 V (1 kΩ)
R48	7030003640	S.RESISTOR	ERJ3GEYJ 473 V (47 kΩ)
R49	7410000950	S.ARRAY	EXB-V8V 102JV
R50	7030003320	S.RESISTOR	ERJ3GEYJ 101 V (100 Ω)
R51	7030003320	S.RESISTOR	ERJ3GEYJ 101 V (100 Ω)
R54	7030003640	S.RESISTOR	ERJ3GEYJ 473 V (47 kΩ)
R55	7030005640	S.RESISTOR	RR0816R-753-D (75 kΩ)
R59	7030003600	S.RESISTOR	ERJ3GEYJ 223 V (22 kΩ)
R60	7030003580	S.RESISTOR	ERJ3GEYJ 153 V (15 kΩ)
R61	7030003680	S.RESISTOR	ERJ3GEYJ 104 V (100 kΩ)
R62	7030003680	S.RESISTOR	ERJ3GEYJ 104 V (100 kΩ)
R63	7030003800	S.RESISTOR	ERJ3GEYJ 105 V (1 MΩ)
R64	7030003800	S.RESISTOR	ERJ3GEYJ 105 V (1 MΩ)
R66	7030003680	S.RESISTOR	ERJ3GEYJ 104 V (100 kΩ)
R67	7030003560	S.RESISTOR	ERJ3GEYJ 103 V (10 kΩ)
R69	7030003280	S.RESISTOR	ERJ3GEYJ 470 V (47 Ω)
R71	7030003320	S.RESISTOR	ERJ3GEYJ 101 V (100 Ω)
R72	7030003680	S.RESISTOR	ERJ3GEYJ 104 V (100 kΩ)
R73	7030003680	S.RESISTOR	ERJ3GEYJ 104 V (100 kΩ)
R74	7030003680	S.RESISTOR	ERJ3GEYJ 104 V (100 kΩ)
R75	7030003800	S.RESISTOR	ERJ3GEYJ 105 V (1 MΩ)
R76	7030003800	S.RESISTOR	ERJ3GEYJ 105 V (1 MΩ)
R77	7030003320	S.RESISTOR	ERJ3GEYJ 101 V (100 Ω)
R78	7030003520	S.RESISTOR	ERJ3GEYJ 472 V (4.7 kΩ)
R81	7030003680	S.RESISTOR	ERJ3GEYJ 104 V (100 kΩ)
R83	7030003560	S.RESISTOR	ERJ3GEYJ 103 V (10 kΩ)
R84	7030003320	S.RESISTOR	ERJ3GEYJ 101 V (100 Ω)
R86	7030003360	S.RESISTOR	ERJ3GEYJ 221 V (220 Ω)
R87	7030003430	S.RESISTOR	ERJ3GEYJ 821 V (820 Ω)
R89	7030003410	S.RESISTOR	ERJ3GEYJ 561 V (560 Ω)
R90	7030003460	S.RESISTOR	ERJ3GEYJ 152 V (1.5 kΩ)
R91	7030003680	S.RESISTOR	ERJ3GEYJ 104 V (100 kΩ)
R92	7030003400	S.RESISTOR	ERJ3GEYJ 471 V (470 Ω)
R93	7030003560	S.RESISTOR	ERJ3GEYJ 103 V (10 kΩ)
R95	7030003460	S.RESISTOR	ERJ3GEYJ 152 V (1.5 kΩ)
R96	7030003470	S.RESISTOR	ERJ3GEYJ 182 V (1.8 kΩ)
R97	7030003400	S.RESISTOR	ERJ3GEYJ 471 V (470 Ω)
R98	7030003680	S.RESISTOR	ERJ3GEYJ 104 V (100 kΩ)
R99	7030003480	S.RESISTOR	ERJ3GEYJ 222 V (2.2 kΩ)
	7030003500	S.RESISTOR	ERJ3GEYJ 332 V (3.3 kΩ) [L-band]
			[H-band]
R100	7030003740	S.RESISTOR	ERJ3GEYJ 334 V (330 kΩ)
R101	7030003390	S.RESISTOR	ERJ3GEYJ 391 V (390 Ω)
R102	7030003460	S.RESISTOR	ERJ3GEYJ 152 V (1.5 kΩ)
R104	7030003200	S.RESISTOR	ERJ3GEYJ 100 V (10 Ω)
R105	7030003580	S.RESISTOR	ERJ3GEYJ 153 V (15 kΩ)
R106	7030003580	S.RESISTOR	ERJ3GEYJ 153 V (15 kΩ)
R107	7030003600	S.RESISTOR	ERJ3GEYJ 223 V (22 kΩ)
R108	7030003600	S.RESISTOR	ERJ3GEYJ 223 V (22 kΩ)

[P]: PMR (F310/F310S), [L]: LMR (F320/F320S)

[MAIN UNIT]

REF NO.	ORDER NO.	DESCRIPTION	
R109	7030003560	S.RESISTOR	ERJ3GEYJ 103 V (10 kΩ)
R110	7030003640	S.RESISTOR	ERJ3GEYJ 473 V (47 kΩ)
R111	7030003320	S.RESISTOR	ERJ3GEYJ 101 V (100 Ω)
R112	7030003320	S.RESISTOR	ERJ3GEYJ 101 V (100 Ω)
R113	7030003510	S.RESISTOR	ERJ3GEYJ 392 V (3.9 kΩ)
R114	7030001230	S.RESISTOR	MCR50JZHJ 680 Ω (681)
R115	7030003560	S.RESISTOR	ERJ3GEYJ 103 V (10 kΩ)
R116	7030003520	S.RESISTOR	ERJ3GEYJ 472 V (4.7 kΩ)
R117	7030003700	S.RESISTOR	ERJ3GEYJ 154 V (150 kΩ)
R118	7030003580	S.RESISTOR	ERJ3GEYJ 153 V (15 kΩ)
R119	7030005870	S.RESISTOR	RR0816R-104-D (100 kΩ)
R120	7030003520	S.RESISTOR	ERJ3GEYJ 472 V (4.7 kΩ)
R121	7030005650	S.RESISTOR	RR0816R-304-D (300 kΩ)
R122	7030005640	S.RESISTOR	RR0816R-753-D (75 kΩ)
R123	7030003540	S.RESISTOR	ERJ3GEYJ 822 V (6.8 kΩ)
R124	7030003680	S.RESISTOR	ERJ3GEYJ 104 V (100 kΩ)
R125	7030003200	S.RESISTOR	ERJ3GEYJ 100 V (10 Ω)
R126	7030003560	S.RESISTOR	ERJ3GEYJ 103 V (10 kΩ)
R127	7030003680	S.RESISTOR	ERJ3GEYJ 104 V (100 kΩ)
R128	7030003680	S.RESISTOR	ERJ3GEYJ 104 V (100 kΩ)
R129	7030003410	S.RESISTOR	ERJ3GEYJ 561 V (560 Ω)
R130	7030003560	S.RESISTOR	ERJ3GEYJ 103 V (10 kΩ)
R131	7030003660	S.RESISTOR	ERJ3GEYJ 683 V (68 kΩ)
R133	7030003640	S.RESISTOR	ERJ3GEYJ 473 V (47 kΩ)
R134	7030003520	S.RESISTOR	ERJ3GEYJ 472 V (4.7 kΩ)
R135	7030003610	S.RESISTOR	ERJ3GEYJ 273 V (27 kΩ)
R136	7030003660	S.RESISTOR	ERJ3GEYJ 683 V (68 kΩ)
R137	7030003800	S.RESISTOR	ERJ3GEYJ 105 V (1 MΩ)
R139	7030003800	S.RESISTOR	ERJ3GEYJ 105 V (1 MΩ)
R140	7030003320	S.RESISTOR	ERJ3GEYJ 101 V (100 Ω)
R141	7030005870	S.RESISTOR	RR0816R-104-D (100 kΩ)
R142	7030005870	S.RESISTOR	RR0816R-104-D (100 kΩ)
R143	7030005870	S.RESISTOR	RR0816R-104-D (100 kΩ)
R145	7030003560	S.RESISTOR	ERJ3GEYJ 103 V (10 kΩ)
R146	7030003660	S.RESISTOR	ERJ3GEYJ 683 V (68 kΩ)
R147	7030003710	S.RESISTOR	ERJ3GEYJ 184 V (180 kΩ)
R148	7030003650	S.RESISTOR	ERJ3GEYJ 563 V (56 kΩ)
R149	7030003710	S.RESISTOR	ERJ3GEYJ 184 V (180 kΩ)
R150	7030003720	S.RESISTOR	ERJ3GEYJ 224 V (220 kΩ)
R151	7030003560	S.RESISTOR	ERJ3GEYJ 103 V (10 kΩ)
R152	7030003560	S.RESISTOR	ERJ3GEYJ 103 V (10 kΩ)
R153	7030003560	S.RESISTOR	ERJ3GEYJ 103 V (10 kΩ)
R154	7030003680	S.RESISTOR	ERJ3GEYJ 104 V (100 kΩ)
R155	7030003560	S.RESISTOR	ERJ3GEYJ 103 V (10 kΩ)
R156	7030003770	S.RESISTOR	ERJ3GEYJ 564 V (560 kΩ)
R157	7030003480	S.RESISTOR	ERJ3GEYJ 222 V (2.2 kΩ)
R158	7030003780	S.RESISTOR	ERJ3GEYJ 684 V (680 kΩ)
R159	7030003560	S.RESISTOR	ERJ3GEYJ 103 V (10 kΩ)
R160	7030003580	S.RESISTOR	ERJ3GEYJ 153 V (15 kΩ)
R161	7030003760	S.RESISTOR	ERJ3GEYJ 474 V (470 kΩ)
R162	7030003660	S.RESISTOR	ERJ3GEYJ 683 V (68 kΩ)
R163	7030003800	S.RESISTOR	ERJ3GEYJ 105 V (1 MΩ)
R164	7030003520	S.RESISTOR	ERJ3GEYJ 472 V (4.7 kΩ)
R165	7030003640	S.RESISTOR	ERJ3GEYJ 473 V (47 kΩ)
R166	7030003690	S.RESISTOR	ERJ3GEYJ 124 V (120 kΩ)
R167	7030003520	S.RESISTOR	ERJ3GEYJ 472 V (4.7 kΩ)
R168	7030003800	S.RESISTOR	ERJ3GEYJ 105 V (1 MΩ)
R169	7030003480	S.RESISTOR	ERJ3GEYJ 222 V (2.2 kΩ)
R170	7030003800	S.RESISTOR	ERJ3GEYJ 105 V (1 MΩ)
R171	7030003800	S.RESISTOR	ERJ3GEYJ 105 V (1 MΩ)
R172	7030003580	S.RESISTOR	ERJ3GEYJ 153 V (15 kΩ)
R174	7030003700	S.RESISTOR	ERJ3GEYJ 154 V (150 kΩ)
R175	7030003560	S.RESISTOR	ERJ3GEYJ 103 V (10 kΩ)
R176	7030003780	S.RESISTOR	ERJ3GEYJ 684 V (680 kΩ)
R177	7030003640	S.RESISTOR	ERJ3GEYJ 473 V (47 kΩ)
R178	7030003620	S.RESISTOR	ERJ3GEYJ 333 V (33 kΩ)
R179	7030003700	S.RESISTOR	ERJ3GEYJ 154 V (150 kΩ)
R180	7030003630	S.RESISTOR	ERJ3GEYJ 393 V (39 kΩ)
R181	7030003520	S.RESISTOR	ERJ3GEYJ 472 V (4.7 kΩ)
R182	7030003640	S.RESISTOR	ERJ3GEYJ 473 V (47 kΩ)
R183	7030003680	S.RESISTOR	ERJ3GEYJ 104 V (100 kΩ)
R184	7030003680	S.RESISTOR	ERJ3GEYJ 104 V (100 kΩ)
R185	7510000910	S.THERMISTOR	NTCCF2012 4AH 473KC-T
R186	7030005870	S.RESISTOR	RR0816R-104-D (100 kΩ)
R187	7030003800	S.RESISTOR	ERJ3GEYJ 105 V (1 MΩ)
R188	7030003800	S.RESISTOR	ERJ3GEYJ 105 V (1 MΩ)
R189	7030003800	S.RESISTOR	ERJ3GEYJ 105 V (1 MΩ)
R190	7030003680	S.RESISTOR	ERJ3GEYJ 104 V (100 kΩ)
R191	7030003680	S.RESISTOR	ERJ3GEYJ 104 V (100 kΩ)
R192	7030003680	S.RESISTOR	ERJ3GEYJ 104 V (100 kΩ)
R193	7030003480	S.RESISTOR	ERJ3GEYJ 222 V (2.2 kΩ)

S.=Surface mount

[MAIN UNIT]

REF NO.	ORDER NO.	DESCRIPTION	
R194	7030003560	S.RESISTOR	ERJ3GEYJ 103 V (10 kΩ)
R195	7030003560	S.RESISTOR	ERJ3GEYJ 103 V (10 kΩ)
R196	7030003640	S.RESISTOR	ERJ3GEYJ 473 V (47 kΩ)
R197	7030001250	S.RESISTOR	MCR50JZHJ 1 kΩ (102)
R198	7030003640	S.RESISTOR	ERJ3GEYJ 473 V (47 kΩ)
R199	7030003520	S.RESISTOR	ERJ3GEYJ 472 V (4.7 kΩ)
R200	7030003640	S.RESISTOR	ERJ3GEYJ 473 V (47 kΩ)
R201	7030003440	S.RESISTOR	ERJ3GEYJ 102 V (1 kΩ)
R202	7030003560	S.RESISTOR	ERJ3GEYJ 103 V (10 kΩ)
R203	7030003520	S.RESISTOR	ERJ3GEYJ 472 V (4.7 kΩ)
R204	7030003440	S.RESISTOR	ERJ3GEYJ 102 V (1 kΩ)
R205	7030005650	S.RESISTOR	RR0816R-304-D (300 kΩ)
R206	7030005870	S.RESISTOR	RR0816R-104-D (100 kΩ)
R207	7030003680	S.RESISTOR	ERJ3GEYJ 104 V (100 kΩ)
R208	7030003800	S.RESISTOR	ERJ3GEYJ 105 V (1 MΩ)
R209	7030003800	S.RESISTOR	ERJ3GEYJ 105 V (1 MΩ)
R210	7030003800	S.RESISTOR	ERJ3GEYJ 105 V (1 MΩ)
R211	7030003480	S.RESISTOR	ERJ3GEYJ 222 V (2.2 kΩ)
R212	7410000950	S.ARRAY	EXB-V8V 102JV
R213	7410000950	S.ARRAY	EXB-V8V 102JV
R214	7410000950	S.ARRAY	EXB-V8V 102JV
R215	7410000950	S.ARRAY	EXB-V8V 102JV
R216	7410000950	S.ARRAY	EXB-V8V 102JV
R217	7410000950	S.ARRAY	EXB-V8V 102JV
R218	7410000950	S.ARRAY	EXB-V8V 102JV
R219	7410000950	S.ARRAY	EXB-V8V 102JV
R220	7030003320	S.RESISTOR	ERJ3GEYJ 101 V (100 Ω)
R221	7030000950	S.RESISTOR	MCR18EZHJ 22 Ω (220)
R222	7030003640	S.RESISTOR	ERJ3GEYJ 473 V (47 kΩ)
R223	7030003620	S.RESISTOR	ERJ3GEYJ 333 V (33 kΩ)
R226	7030003710	S.RESISTOR	ERJ3GEYJ 184 V (180 kΩ)
R227	7030003780	S.RESISTOR	ERJ3GEYJ 684 V (680 kΩ)
R228	7030003590	S.RESISTOR	ERJ3GEYJ 183 V (18 kΩ)
R229	7030003640	S.RESISTOR	ERJ3GEYJ 473 V (47 kΩ)
R230	7030003400	S.RESISTOR	ERJ3GEYJ 471 V (470 Ω)
R232	7030003760	S.RESISTOR	ERJ3GEYJ 474 V (470 kΩ)
R233	7030003440	S.RESISTOR	ERJ3GEYJ 102 V (1 kΩ)
R234	7030003680	S.RESISTOR	ERJ3GEYJ 104 V (100 kΩ)
R235	7030003560	S.RESISTOR	ERJ3GEYJ 103 V (10 kΩ)
R236	7030003680	S.RESISTOR	ERJ3GEYJ 104 V (100 kΩ)
R237	7030003440	S.RESISTOR	ERJ3GEYJ 102 V (1 kΩ)
R238	7030003590	S.RESISTOR	ERJ3GEYJ 183 V (18 kΩ)
R240	7030003540	S.RESISTOR	ERJ3GEYJ 682 V (6.8 kΩ)
R241	7030003680	S.RESISTOR	ERJ3GEYJ 104 V (100 kΩ)
R242	7030003400	S.RESISTOR	ERJ3GEYJ 471 V (470 Ω)
R243	7030001730	S.RESISTOR	MCR18EZHJ 68 Ω (680)
R245	7030003560	S.RESISTOR	ERJ3GEYJ 103 V (10 kΩ)
R246	7030003340	S.RESISTOR	ERJ3GEYJ 151 V (150 Ω)
R247	7030003410	S.RESISTOR	ERJ3GEYJ 561 V (560 Ω)
R248	7030003640	S.RESISTOR	ERJ3GEYJ 473 V (47 kΩ)
R249	7030003560	S.RESISTOR	RR0816R-334-D (330 kΩ)
R251	7520000170	S.POSISTOR	PTH9C32BB471Q-T only
R252	7030003580	S.RESISTOR	ERJ3GEYJ 153 V (15 kΩ)
C1	4030011070	S.CERAMIC	GRM42-6 CH 050C 500PT
C3	4030011040	S.CERAMIC	GRM42-6 CK 020C 500PT
C4	4030011080	S.CERAMIC	GRM42-6 CH 060D 500PT
C5	4030011170	S.CERAMIC	GRM42-6 CH 180J 500PT
C7	4030011340	S.CERAMIC	C1608 CH 1H 471J-T-A
C8	4030011140	S.CERAMIC	GRM42-6 CH 120J 500PT
C9	4030011120	S.CERAMIC	GRM42-6 CH 100D 500PT
C10	4030011100	S.CERAMIC	GRM42-6 CH 080D 500PT
C11	4030011160	S.CERAMIC	GRM42-6 CH 150J 500PT
C13	4030011220	S.CERAMIC	GRM42-6 CH 200J 500PT
C15	4030011260	S.CERAMIC	GRM42-6 W5R 102K 500PT

[MAIN UNIT]

REF NO.	ORDER NO.	DESCRIPTION	
C16	4030011340	S.CERAMIC	C1608 CH 1H 471J-T-A
C17	4030006860	S.CERAMIC	C1608 JB 1H 102K-T-A
C18	4030011340	S.CERAMIC	C1608 CH 1H 471J-T-A
C19	4030006860	S.CERAMIC	C1608 JB 1H 102K-T-A
C20	4030011180	S.CERAMIC	GRM42-6 CH 220J 500PT
C22	4030011270	S.CERAMIC	GRM42-6 CH 200J 500PT
C23	4030011170	S.CERAMIC	GRM42-6 CH 180J 500PT
C23	4030011180	S.CERAMIC	GRM42-6 CH 220J 500PT
C23	4030011270	S.CERAMIC	GRM42-6 CH 200J 500PT
C23	4030011170	S.CERAMIC	GRM42-6 CH 180J 500PT
C23	4030007040	S.CERAMIC	C1608 CH 1H 180J-T-A
C24	4030006990	S.CERAMIC	C1608 CH 1H 080D-T-A
C24	4030007020	S.CERAMIC	C1608 CH 1H 120J-T-A
C24	4030008750	S.CERAMIC	C1608 CH 1H 360J-T-A
C24	4030007060	S.CERAMIC	C1608 CH 1H 270J-T-A
C25	4030007040	S.CERAMIC	C1608 CH 1H 180J-T-A
C25	4030007020	S.CERAMIC	C1608 CH 1H 120J-T-A
C26	4030006860	S.CERAMIC	C1608 JB 1H 102K-T-A
C27	4030006860	S.CERAMIC	C1608 JB 1H 102K-T-A
C28	4030011340	S.CERAMIC	C1608 CH 1H 471J-T-A
C29	4030007040	S.CERAMIC	C1608 CH 1H 180J-T-A
C30	4030007050	S.CERAMIC	C1608 CH 1H 220J-T-A
C30	4030006860	S.CERAMIC	C1608 JB 1H 102K-T-A
C31	4030011340	S.CERAMIC	C1608 CH 1H 471J-T-A
C32	4030006860	S.CERAMIC	C1608 JB 1H 102K-T-A
C33	4030007030	S.CERAMIC	C1608 CH 1H 150J-T-A
C33	4030007040	S.CERAMIC	C1608 CH 1H 180J-T-A
C35	4030006860	S.CERAMIC	C1608 CH 1H 080D-T-A
C35	4030006860	S.CERAMIC	C1608 JB 1H 102K-T-A
C36	4030007090	S.CERAMIC	C1608 CH 1H 470J-T-A
C37	4030006860	S.CERAMIC	C1608 JB 1H 102K-T-A
C38	4030006860	S.CERAMIC	C1608 JB 1H 102K-T-A
C39	4030007010	S.CERAMIC	C1608 CH 1H 100D-T-A
C40	4030006860	S.CERAMIC	C1608 JB 1H 102K-T-A
C41	4030007040	S.CERAMIC	C1608 CH 1H 180J-T-A
C42	4030006860	S.CERAMIC	C1608 JB 1H 102K-T-A
C43	4030007020	S.CERAMIC	C1608 CH 1H 120J-T-A
C44	4030006860	S.CERAMIC	C1608 JB 1H 102K-T-A
C45	4030009920	S.CERAMIC	C1608 CH 1H 050B-T-A
C46	4030007050	S.CERAMIC	C1608 CH 1H 220J-T-A
C47	4030006860	S.CERAMIC	C1608 JB 1H 102K-T-A
C48	4030009500	S.CERAMIC	C1608 CH 1H 0R5B-T-A
C49	4030006860	S.CERAMIC	C1608 JB 1H 102K-T-A
C50	4030006860	S.CERAMIC	C1608 JB 1H 102K-T-A
C51	4030006860	S.CERAMIC	C1608 JB 1H 102K-T-A
C52	4030009520	S.CERAMIC	C1608 CH 1H 020B-T-A
C53	4030009540	S.CERAMIC	C1608 CH 1H 1R5B-T-A
C54	4030008360	S.CERAMIC	C1608 UJ 1H 101J-T-A
C55	4030008330	S.CERAMIC	C1608 UJ 1H 560J-T-A
C55	4030008300	S.CERAMIC	C1608 UJ 1H 330J-T-A
C56	4030006860	S.CERAMIC	C1608 JB 1H 102K-T-A
C57	4030006860	S.CERAMIC	C1608 JB 1H 102K-T-A
C58	4030006860	S.CERAMIC	C1608 JB 1H 102K-T-A
C59	4030011600	S.CERAMIC	C1608 JB 1C 104KT-N
C60	4550006170	S.TANTALUM	ECST1AY225R
C61	4550006590	S.TANTALUM	ECST1CY684R
C62	4030006860	S.CERAMIC	C1608 JB 1H 102K-T-A
C63	4550006200	S.TANTALUM	ECST0JY106
C64	4030006860	S.CERAMIC	C1608 JB 1H 102K-T-A
C65	4030006860	S.CERAMIC	C1608 JB 1H 102K-T-A
C66	4030006860	S.CERAMIC	C1608 JB 1H 102K-T-A
C67	4030006860	S.CERAMIC	C1608 JB 1H 102K-T-A
C68	4030006900	S.CERAMIC	C1608 JB 1E 103K-T-A
C69	4030006860	S.CERAMIC	C1608 JB 1H 102K-T-A
C70	4030007090	S.CERAMIC	C1608 CH 1H 470J-T-A

[P]: PMR (F310/F310S), [L]: LMR (F320/F320S)

S.=Surface mount

[MAIN UNIT]

REF NO.	ORDER NO.	DESCRIPTION	
C71	4030007090	S.CERAMIC	C1608 CH 1H 470J-T-A
C72	4030007090	S.CERAMIC	C1608 CH 1H 470J-T-A
C73	4030006860	S.CERAMIC	C1608 JB 1H 102K-T-A
C74	4030009990	S.CERAMIC	C1608 CH 1H 200J-T-A
			[L-band]
	4030007000	S.CERAMIC	C1608 CH 1H 090D-T-A
			[H-band]
C75	4030007000	S.CERAMIC	C1608 CH 1H 090D-T-A
			[H-band] only
C79	4030007100	S.CERAMIC	C1608 CH 1H 560J-T-A
C80	4030007020	S.CERAMIC	C1608 CH 1H 120J-T-A
C82	4030007070	S.CERAMIC	C1608 CH 1H 330J-T-A
C85	4550006170	S.TANTALUM	ECST1AY225R
C86	4030006860	S.CERAMIC	C1608 JB 1H 102K-T-A
C87	4030011160	S.CERAMIC	GRM42-6 CH 150J 500PT P
	4030011170	S.CERAMIC	GRM42-6 CH 180J 500PT L
C88	4030011180	S.CERAMIC	GRM42-6 CH 220J 500PT
C89	4030006980	S.CERAMIC	C1608 CH 1H 070D-T-A
C90	4030009910	S.CERAMIC	C1608 CH 1H 040B-T-A
C91	4030009910	S.CERAMIC	C1608 CH 1H 040B-T-A
			[L-band]
	4030009540	S.CERAMIC	C1608 CH 1H 1R5B-T-A
			[H-band]
C92	4030007150	S.CERAMIC	C1608 CH 1H 151J-T-A
			[L-band]
	4030007130	S.CERAMIC	C1608 CH 1H 101J-T-A
			[H-band]
C93	4030009510	S.CERAMIC	C1608 CH 1H 010B-T-A
C95	4030006860	S.CERAMIC	C1608 JB 1H 102K-T-A
C96	4030006860	S.CERAMIC	C1608 JB 1H 102K-T-A
C97	4030007170	S.CERAMIC	C1608 CH 1H 221J-T-A
			[L-band]
	4030007130	S.CERAMIC	C1608 CH 1H 101J-T-A
			[H-band]
C98	4030007000	S.CERAMIC	C1608 CH 1H 090D-T-A
			[L-band]
	4030011770	S.CERAMIC	C1608 CH 1H 060B-T-A
			[H-band]
C99	4030009540	S.CERAMIC	C1608 CH 1H 1R5B-T-A
C100	4030006860	S.CERAMIC	C1608 JB 1H 102K-T-A
C101	4030006860	S.CERAMIC	C1608 JB 1H 102K-T-A
C102	4030006900	S.CERAMIC	C1608 JB 1E 103K-T-A
C103	4030006860	S.CERAMIC	C1608 JB 1H 102K-T-A
C104	4030006860	S.CERAMIC	C1608 JB 1H 102K-T-A
C105	4030011770	S.CERAMIC	C1608 CH 1H 060B-T-A
			[L-band]
	4030009910	S.CERAMIC	C1608 CH 1H 040B-T-A
			[H-band]
C106	4030007140	S.CERAMIC	C1608 CH 1H 121J-T-A
			[L-band]
	4030007130	S.CERAMIC	C1608 CH 1H 101J-T-A
			[H-band]
C107	4030009510	S.CERAMIC	C1608 CH 1H 010B-T-A
C109	4030006860	S.CERAMIC	C1608 JB 1H 102K-T-A
C110	4030006860	S.CERAMIC	C1608 JB 1H 102K-T-A
C111	4030007140	S.CERAMIC	C1608 CH 1H 121J-T-A
			[L-band]
	4030007130	S.CERAMIC	C1608 CH 1H 101J-T-A
			[H-band]
C112	4030007030	S.CERAMIC	C1608 CH 1H 150J-T-A
			[L-band]
	4030006990	S.CERAMIC	C1608 CH 1H 080D-T-A
			[H-band]
C113	4030009920	S.CERAMIC	C1608 CH 1H 050B-T-A
C115	4030006860	S.CERAMIC	C1608 JB 1H 102K-T-A
C116	4030007030	S.CERAMIC	C1608 CH 1H 150J-T-A
C117	4030007100	S.CERAMIC	C1608 CH 1H 560J-T-A
C118	4030007030	S.CERAMIC	C1608 CH 1H 150J-T-A
C119	4030006900	S.CERAMIC	C1608 JB 1E 103K-T-A
C120	4030006860	S.CERAMIC	C1608 JB 1H 102K-T-A
C121	4030007110	S.CERAMIC	C1608 CH 1H 680J-T-A
C122	4030006860	S.CERAMIC	C1608 JB 1H 102K-T-A
C123	4030006900	S.CERAMIC	C1608 JB 1E 103K-T-A
C124	4030006860	S.CERAMIC	C1608 JB 1H 102K-T-A
C126	4030011530	S.CERAMIC	C1608 CH 1H 110J-T-A
C127	4030006900	S.CERAMIC	C1608 JB 1E 103K-T-A
C128	4030006900	S.CERAMIC	C1608 JB 1E 103K-T-A
C129	4030006900	S.CERAMIC	C1608 JB 1E 103K-T-A
C130	4030006900	S.CERAMIC	C1608 JB 1E 103K-T-A
C131	4030007130	S.CERAMIC	C1608 CH 1H 101J-T-A
C132	4030006860	S.CERAMIC	C1608 JB 1H 102K-T-A

P: PMR (F310/F310S), L: LMR (F320/F320S)

[MAIN UNIT]

REF NO.	ORDER NO.	DESCRIPTION	
C133	4030008900	S.CERAMIC	C1608 JB 1C 333K-T-A
C134	4030006860	S.CERAMIC	C1608 JB 1H 102K-T-A
C135	4030006900	S.CERAMIC	C1608 JB 1E 103K-T-A
C136	4030008680	S.CERAMIC	C2012 JF 1C 105Z-T-A
C137	4030011600	S.CERAMIC	C1608 JB 1C 104KT-N
C138	4030007170	S.CERAMIC	C1608 CH 1H 221J-T-A
C139	4030007170	S.CERAMIC	C1608 CH 1H 221J-T-A
C140	4030007010	S.CERAMIC	C1608 CH 1H 100D-T-A
C141	4030007040	S.CERAMIC	C1608 CH 1H 180J-T-A
C142	4030009910	S.CERAMIC	C1608 CH 1H 040B-T-A
C143	4030007020	S.CERAMIC	C1608 CH 1H 120J-T-A
C144	4030007030	S.CERAMIC	C1608 CH 1H 150J-T-A
C145	4030007010	S.CERAMIC	C1608 CH 1H 100D-T-A
C146	4030006900	S.CERAMIC	C1608 JB 1E 103K-T-A
C147	4030006900	S.CERAMIC	C1608 JB 1E 103K-T-A
C148	4030011600	S.CERAMIC	C1608 JB 1C 104KT-N
C149	4030011600	S.CERAMIC	C1608 JB 1C 104KT-N
C150	4030006860	S.CERAMIC	C1608 JB 1H 102K-T-A
C151	4030006860	S.CERAMIC	C1608 JB 1H 102K-T-A
C152	4030006860	S.CERAMIC	C1608 JB 1H 102K-T-A
C153	4030006860	S.CERAMIC	C1608 JB 1H 102K-T-A
C154	4030011340	S.CERAMIC	C1608 CH 1H 471J-T-A
C155	4030006860	S.CERAMIC	C1608 JB 1H 102K-T-A
C156	4550006170	S.TANTALUM	ECST1AY225R
			except L [H-band]
C157	4030006860	S.CERAMIC	C1608 JB 1H 102K-T-A
C159	4030006900	S.CERAMIC	C1608 JB 1E 103K-T-A
C160	4030006860	S.CERAMIC	C1608 JB 1H 102K-T-A
C161	4030011600	S.CERAMIC	C1608 JB 1C 104KT-N
C162	4030006900	S.CERAMIC	C1608 JB 1E 103K-T-A
C163	4030012600	S.CERAMIC	C2012 JB 1A 105M-T-A
C164	4030008880	S.CERAMIC	C1608 CH 1C 223K-T-A
C165	4030006900	S.CERAMIC	C1608 JB 1E 103K-T-A
C166	4550006170	S.TANTALUM	ECST1AY225R
C167	4030006900	S.CERAMIC	C1608 JB 1E 103K-T-A
C168	4030011600	S.CERAMIC	C1608 JB 1C 104KT-N
C169	4030006900	S.CERAMIC	C1608 JB 1E 103K-T-A
C170	4030006900	S.CERAMIC	C1608 JB 1E 103K-T-A
C171	4030006860	S.CERAMIC	C1608 JB 1H 102K-T-A
C172	4030010750	S.CERAMIC	C1608 CH 1H 201J-T-A
C173	4030006860	S.CERAMIC	C1608 JB 1H 102K-T-A
C174	4030006900	S.CERAMIC	C1608 JB 1E 103K-T-A
C175	4030006900	S.CERAMIC	C1608 JB 1E 103K-T-A
C176	4030006900	S.CERAMIC	C1608 JB 1E 103K-T-A
C177	4030006900	S.CERAMIC	C1608 JB 1E 103K-T-A
C178	4030006860	S.CERAMIC	C1608 JB 1H 102K-T-A
C179	4030006860	S.CERAMIC	C1608 JB 1H 102K-T-A
C180	4030006860	S.CERAMIC	C1608 JB 1H 102K-T-A
C181	4030006860	S.CERAMIC	C1608 JB 1H 102K-T-A
C182	4550006200	S.TANTALUM	ECST0JY106R
C183	4030006900	S.CERAMIC	C1608 JB 1E 103K-T-A
C184	4550006170	S.TANTALUM	ECST1AY225R
C185	4030011600	S.CERAMIC	C1608 JB 1C 104KT-N
C186	4030011600	S.CERAMIC	C1608 JB 1C 104KT-N
C187	4030006900	S.CERAMIC	C1608 JB 1E 103K-T-A
C188	4030011810	S.CERAMIC	C1608 JB 1A 224K-T-N
C189	4030006900	S.CERAMIC	C1608 JB 1E 103K-T-A
C190	4030006900	S.CERAMIC	C1608 JB 1E 103K-T-A
C191	4030006900	S.CERAMIC	C1608 JB 1E 103K-T-A
C192	4030006900	S.CERAMIC	C1608 JB 1E 103K-T-A
C194	4550006170	S.TANTALUM	ECST1AY225R
C196	4030011600	S.CERAMIC	C1608 JB 1C 104KT-N
C197	4030011600	S.CERAMIC	C1608 JB 1C 104KT-N
C198	4030007130	S.CERAMIC	C1608 CH 1H 101J-T-A
C199	4030011600	S.CERAMIC	C1608 JB 1C 104KT-N
C200	4030011810	S.CERAMIC	C1608 JB 1A 224K-T-N
C201	4550006200	S.TANTALUM	ECST0JY106R
C202	4030006860	S.CERAMIC	C1608 JB 1H 102K-T-A
C203	4030006900	S.CERAMIC	C1608 JB 1E 103K-T-A
C204	4510005290	S.ELECTROLYTIC	ECEV1EA221P
C205	4030011600	S.CERAMIC	C1608 JB 1C 104KT-N
C206	4510006260	S.ELECTROLYTIC	ECEV1AA471UP
C207	4510005310	S.ELECTROLYTIC	ECEV1CA220SR
C208	4030006860	S.CERAMIC	C1608 JB 1H 102K-T-A
C209	4510005310	S.ELECTROLYTIC	ECEV1CA220SR
C210	4030006860	S.CERAMIC	C1608 JB 1H 102K-T-A
C211	4510005310	S.ELECTROLYTIC	ECEV1CA220SR
C212	4030006860	S.CERAMIC	C1608 JB 1H 102K-T-A
C213	4030006860	S.CERAMIC	C1608 JB 1H 102K-T-A
C215	4550006200	S.TANTALUM	ECST0JY106R
C216	4510005320	S.ELECTROLYTIC	ECEV0JA101SP

S.=Surface mount

[MAIN UNIT]

REF NO.	ORDER NO.	DESCRIPTION	
C217	4030006900	S.CERAMIC	C1608 JB 1E 103K-T-A
C218	4030006900	S.CERAMIC	C1608 JB 1E 103K-T-A
C219	4030006860	S.CERAMIC	C1608 JB 1H 102K-T-A
C220	4510004510	ELECTROLYTIC	25 MV 470 HC
C221	4030006860	S.CERAMIC	C1608 JB 1H 102K-T-A
C222	4030011340	S.CERAMIC	C1608 CH 1H 471J-T-A
C223	4030007090	S.CERAMIC	C1608 CH 1H 470J-T-A
C224	4030006860	S.CERAMIC	C1608 JB 1H 102K-T-A
C225	4030006860	S.CERAMIC	C1608 JB 1H 102K-T-A
C226	4030006860	S.CERAMIC	C1608 JB 1H 102K-T-A
C227	4030006860	S.CERAMIC	C1608 JB 1H 102K-T-A
C228	4030006860	S.CERAMIC	C1608 JB 1H 102K-T-A
C229	4550006150	S.TANTALUM	ECST1CY105R
C230	4030011810	S.CERAMIC	C1608 JB 1A 224K-T-N
C231	4030006860	S.CERAMIC	C1608 JB 1H 102K-T-A
C232	4030006860	S.CERAMIC	C1608 JB 1H 102K-T-A
C233	4030006860	S.CERAMIC	C1608 JB 1H 102K-T-A
C234	4030006860	S.CERAMIC	C1608 JB 1H 102K-T-A
C235	4030006860	S.CERAMIC	C1608 JB 1H 102K-T-A
C236	4030006860	S.CERAMIC	C1608 JB 1H 102K-T-A
C237	4030006860	S.CERAMIC	C1608 JB 1H 102K-T-A
C238	4030006860	S.CERAMIC	C1608 JB 1H 102K-T-A
C240	4030007090	S.CERAMIC	C1608 CH 1H 470J-T-A
C241	4030007090	S.CERAMIC	C1608 CH 1H 470J-T-A
C242	4030007090	S.CERAMIC	C1608 CH 1H 470J-T-A
C243	4030007090	S.CERAMIC	C1608 CH 1H 470J-T-A
C244	4030007090	S.CERAMIC	C1608 CH 1H 470J-T-A
C245	4030007090	S.CERAMIC	C1608 CH 1H 470J-T-A
C246	4030007090	S.CERAMIC	C1608 CH 1H 470J-T-A
C248	4030007090	S.CERAMIC	C1608 CH 1H 470J-T-A
C249	4030007090	S.CERAMIC	C1608 CH 1H 470J-T-A
C250	4030007090	S.CERAMIC	C1608 CH 1H 470J-T-A
C251	4030007090	S.CERAMIC	C1608 CH 1H 470J-T-A
C252	4030007090	S.CERAMIC	C1608 CH 1H 470J-T-A
C253	4030007090	S.CERAMIC	C1608 CH 1H 470J-T-A
C254	4030007090	S.CERAMIC	C1608 CH 1H 470J-T-A
C255	4030007090	S.CERAMIC	C1608 CH 1H 470J-T-A
C256	4030007090	S.CERAMIC	C1608 CH 1H 470J-T-A
C257	4030007090	S.CERAMIC	C1608 CH 1H 470J-T-A
C258	4030007090	S.CERAMIC	C1608 CH 1H 470J-T-A
C259	4030007090	S.CERAMIC	C1608 CH 1H 470J-T-A
C260	4030007090	S.CERAMIC	C1608 CH 1H 470J-T-A
C261	4030007090	S.CERAMIC	C1608 CH 1H 470J-T-A
C262	4030007090	S.CERAMIC	C1608 CH 1H 470J-T-A
C263	4030007090	S.CERAMIC	C1608 CH 1H 470J-T-A
C264	4030007090	S.CERAMIC	C1608 CH 1H 470J-T-A
C265	4030007090	S.CERAMIC	C1608 CH 1H 470J-T-A
C266	4030007090	S.CERAMIC	C1608 CH 1H 470J-T-A
C267	4030007090	S.CERAMIC	C1608 CH 1H 470J-T-A
C268	4030007090	S.CERAMIC	C1608 CH 1H 470J-T-A
C269	4030007090	S.CERAMIC	C1608 CH 1H 470J-T-A
C270	4030007090	S.CERAMIC	C1608 CH 1H 470J-T-A
C271	4030006860	S.CERAMIC	C1608 JB 1H 102K-T-A
C272	4030006860	S.CERAMIC	C1608 JB 1H 102K-T-A
C273	4030006860	S.CERAMIC	C1608 JB 1H 102K-T-A
C274	4030011340	S.CERAMIC	C1608 CH 1H 471J-T-A
C275	4030007090	S.CERAMIC	C1608 CH 1H 470J-T-A
C276	4550002830	S.TANTALUM	TESVD2 1V 685M-12R
C277	4030006860	S.CERAMIC	C1608 JB 1H 102K-T-A
C278	4030006860	S.CERAMIC	C1608 JB 1H 102K-T-A
C279	4030011340	S.CERAMIC	C1608 CH 1H 471J-T-A
C280	4030007090	S.CERAMIC	C1608 CH 1H 470J-T-A
C281	4030006860	S.CERAMIC	C1608 JB 1H 102K-T-A
C282	4550006700	S.TANTALUM	ECST1AY106R
C283	4030009970	S.CERAMIC	C1608 JB 1H 182K-T-A
C284	4030011330	S.CERAMIC	C1608 CH 1H 391J-T-A
C285	4030007090	S.CERAMIC	C1608 CH 1H 470J-T-A
C286	4030006860	S.CERAMIC	C1608 JB 1H 102K-T-A
C287	4030007130	S.CERAMIC	C1608 CH 1H 101J-T-A
C288	4030006900	S.CERAMIC	C1608 JB 1E 103K-T-A
C290	4030006900	S.CERAMIC	C1608 JB 1E 103K-T-A
C291	4030007090	S.CERAMIC	C1608 CH 1H 470J-T-A
C292	4030007090	S.CERAMIC	C1608 CH 1H 470J-T-A
C293	4030011600	S.CERAMIC	C1608 JB 1C 104KT-N
C294	4030006900	S.CERAMIC	C1608 JB 1E 103K-T-A
C295	4030006860	S.CERAMIC	C1608 JB 1H 102K-T-A
C296	4030006860	S.CERAMIC	C1608 JB 1H 102K-T-A
C297	4510004590	ELECTROLYTIC	16 MV 470 HC
C298	4550006200	S.TANTALUM	ECST0JY106R
C299	4030006860	S.CERAMIC	C1608 JB 1H 102K-T-A
C301	4030006860	S.CERAMIC	C1608 JB 1H 102K-T-A <input type="checkbox"/> only

[MAIN UNIT]

REF NO.	ORDER NO.	DESCRIPTION	
J1	6510020510	S.CONNECTOR	FH12-40S-0.5SV
J2	6510018430	S.CONNECTOR	AXN330C038P
J3	6510019250	S.CONNECTOR	B11B-ZR-SM3-TF
J4	6510007080	CONNECTOR	PI28A-02M
J5	6450000140	CONNECTOR	HSJ0807-01-010
J6	6510014960	S.CONNECTOR	B2B-ZR-SM3-TF
W1	7120000470	JUMPER	ERDS2T0
W6	7030003860	S.JUMPER	ERJ3GE JPW V
W7	8900007960	CABLE	OPC-780 <input type="checkbox"/> -[EUR, ITA]
	8900004540	CABLE	OPC-453 other
EP1	0910049332	PCB	B 5043B <input type="checkbox"/>
	0910049860	PCB	B 5124 <input type="checkbox"/>

: PMR (F310/F310S), : LMR (F320/F320S)

S.=Surface mount

SECTION 7 MECHANICAL PARTS

[FRONT UNIT]

REF NO.	ORDER NO.	DESCRIPTION	QTY.
J1	6450001470	Connector 95003-2881	1
W3	8900007680	Cable OPC-741	1
DS1	5030001540	LCD LD-HU10140J	1
EP2	8930044930	LCD contact SRCN-2055-SP-N-W	1
MP1	8210015090	2055 LCD reflector © only	1
	8210016090	2266 reflector ⑤ only	1
MP2	8930044110	2055 LCD holder © only	1
	8310045980	2266 plate ⑤ only	1

©: LCD type (F310/F320), ⑤: LED type (F310S/F320S)

[CHASSIS PARTS]

REF NO.	ORDER NO.	DESCRIPTION	QTY.
J1	6510004880	Connector MR-DS-E 01	1
MP1	8010017100	2055 chassis	1
MP2	8210015070	2055 front panel	1
MP3	8930044820	2055 front key (A)	1
MP4	8010017121	2055 cover	1
MP5	8930045070	2055 M-plate	1
MP6	8930046150	Rubber sheet (AK)-1	1
MP7	8810008660	PH BT M3 X 8 NI-ZU	24
MP8	8930044100	2055 speaker plate	1
MP9	8930044761	2055 speaker net-1	1
MP11	8930027480	1126 TR-A clip	2
MP12	8930045390	Sponge (FL)	1
MP13	8930039890	Insulation sheet (EG)	2
MP14	8930049130	Shield tape (D)	2
SP1	2510001030	Speaker VS-57-0837A	1
WS1	8600036040	P1CH	1

[MAIN UNIT]

REF NO.	ORDER NO.	DESCRIPTION	QTY.
J5	6450000140	Connector HSJ0807-01-010	1
W7	8900004540	Cable OPC-453	1
MP1	8510011111	1922 VCO case-1	1
MP2	8510011101	1922 VCO cover-1	1
MP3	8510011460	2055 filter case	1
MP4	8510011610	2055 filter cover	1
MP5	8930015180	PA holder	1
MP6	8930043110	Rubber sheet (AD)	1

[UNPACKING]

REF NO.	ORDER NO.	DESCRIPTION	QTY.
F1	5210000120	Fuse FGB 15A [PMR]	2
	5210000080	Fuse FGB 20A [LMR]	2
W1	Optional product	Cable OPC-345 [PMR]	1
	Optional product	Cable OPC-346 [LMR]	1
W2	Optional product	Cable OPC-049	1
MC1	Optional Product	Microphone HM-100/100T	1
MP1	8010016380	1542 mobil blacket (B)	1
MP3	8820000530	Flange volt M4 X 8 NI	4
MP4	8810000470	PH M5 X 12 NI	4
MP5	8810005840	PH A M5 X 20	4
MP6	8850000150	Flat washer M5 NI BS	4
MP7	8850000390	Spring washer M5	4
MP8	8830000120	Nut M5	4
MP9	6910004210	731 Mic hanger set (incl. screw, washer)	1
MP10	8310042780	Label 1705 LCD seal (A)	1

Screw abbreviations

BT: Self-tapping

PH: Pan head

FH: Flat head

ZK: Black

NI-ZK: Nickel-Zinc

BS: Brass

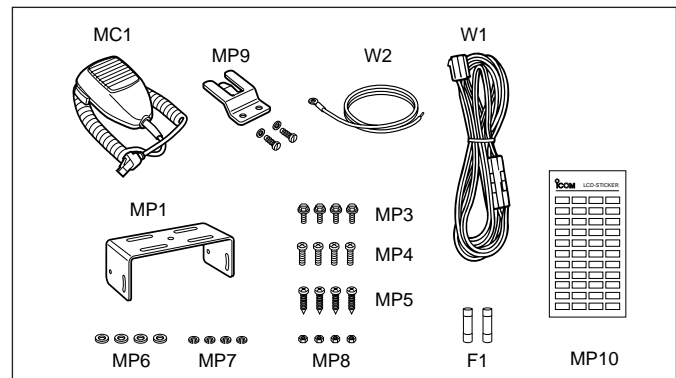

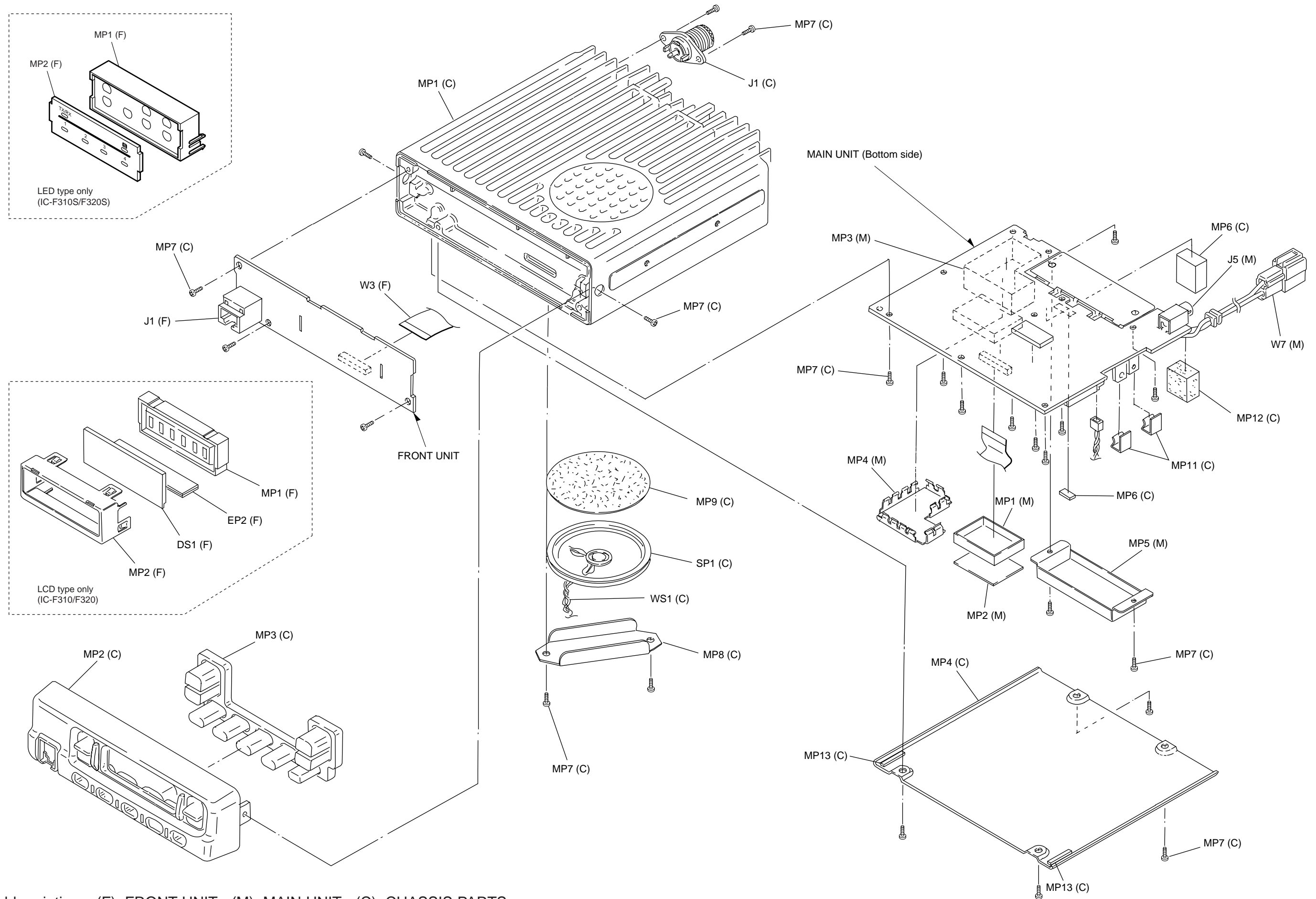

Unit abbreviations (F): FRONT UNIT (M): MAIN UNIT (C): CHASSIS PARTS

SECTION 8 SEMI-CONDUCTOR INFORMATION

• TRANSISTORS AND FET'S

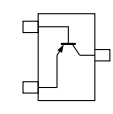
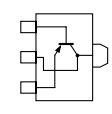
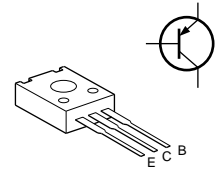
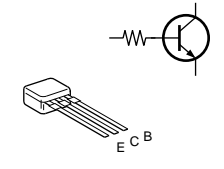
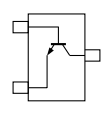
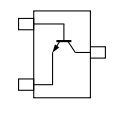
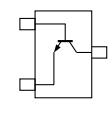
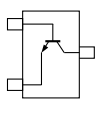
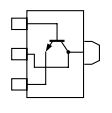
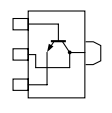
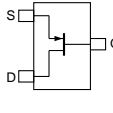
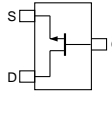
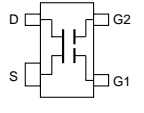
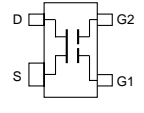
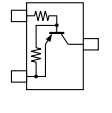
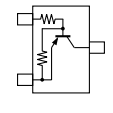
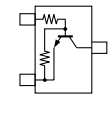
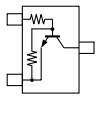
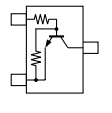
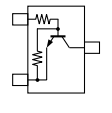
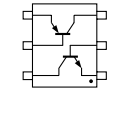
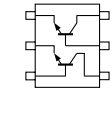
2SA1588 GR (Symbol: ZG) 	2SB1124 S (Symbol: BG) 	2SB1143 S 	2SB1201 S (Symbol: B1201) 	2SC2714 Y (Symbol: QY) 
2SC4081 R (Symbol: BR) 	2SC4215 O (Symbol: QO) 	2SC4226 R25 (Symbol: R25) 	2SC4703 (Symbol: SE) 	2SD1664 (Symbol: DA) 
2SJ144 Y (Symbol: VY) 	2SK880 Y (Symbol: XY) 	3SK166 2 (Symbol: K) 	3SK239 XR (Symbol: XR) 	DTA143ZU (Symbol: 113) 
DTA144EU (Symbol: 16) 	DTC144EU (Symbol: 26) 	DTC144TU (Symbol: 06) 	DTC144WU (Symbol: 86) 	DTC363EK (Symbol: H27) 
XP4601 (Symbol: 5C) 	XP6501 (Symbol: 5N) 			

• DIODES

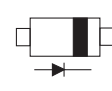
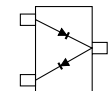
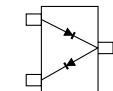
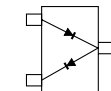
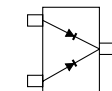
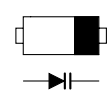
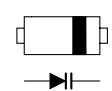
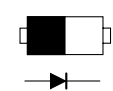
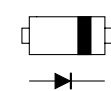
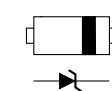
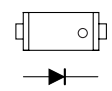
1SS352 (Symbol: C1) 	1SS375 (Symbol: FH) 	DA204U (Symbol: K) 	DA221 (Symbol: K) 	DAN202U (Symbol: N) 
HVU17TRF (Symbol: E) 	HVU350 (Symbol: 4) 	MA77 (Symbol: 4B) 	MA111 (Symbol: 1B) 	MA8082 M (TX) (Symbol: 8-2) 
M1809 (Symbol: Red dot) 				

SECTION 9 BOARD LAYOUTS

9-1 FRONT UNIT (IC-F310/F320)

• TOP VIEW

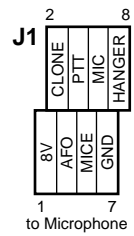
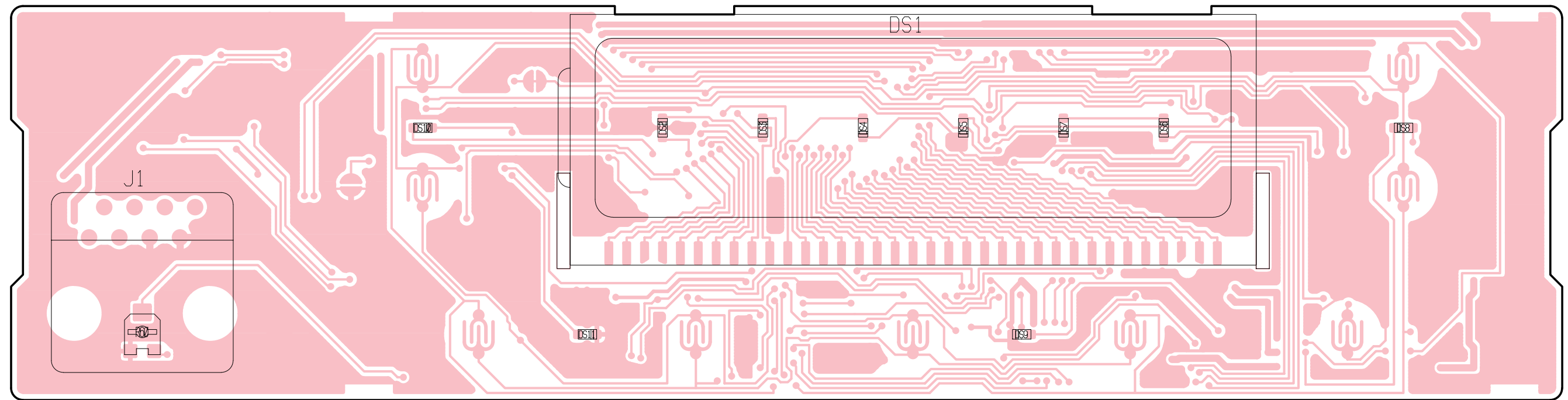

● BOTTOM VIEW

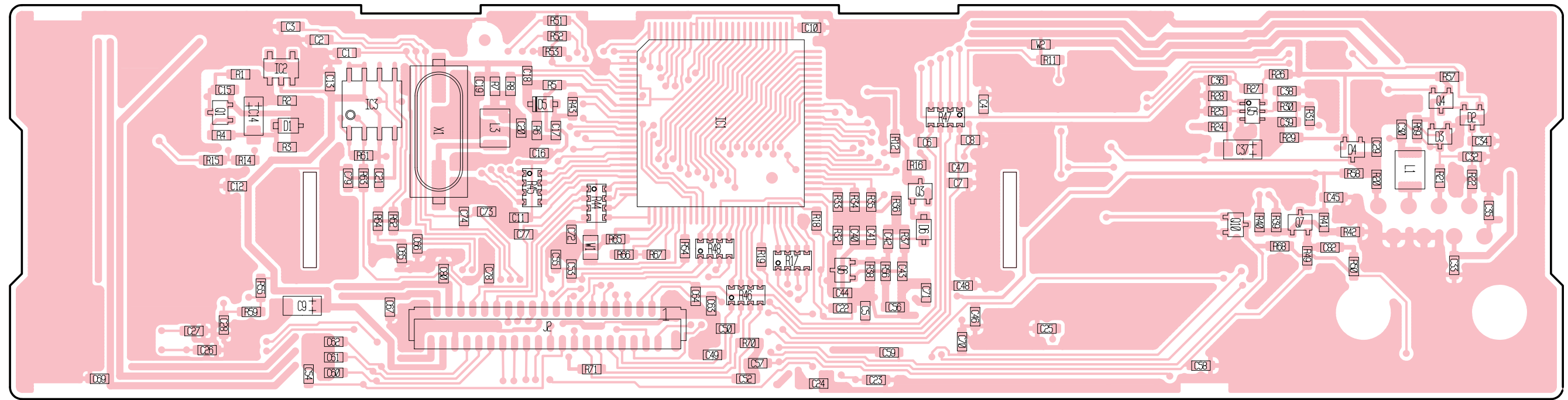

39	5V	AFO	SI	OPT3	OPT2	OPT1	OPV3	OPV2	OPV1	PTT	PTTIN	DET	PWON	EXPTT	DIMIN	SO	SCK	SD	LVIN	GND	1
40	8V	CPU5V	GND	OPINT	OPCS	BUSY	BEEPOUT	BEETONE	BEEP	DTCSIN	RFATT	NOIS	UNLK	EXEN	EXST	DAST	PLST	VIN	TEMP	MIC	2

to MAIN unit J1

9-2 FRONT UNIT (IC-F310S/F320S)

● TOP VIEW

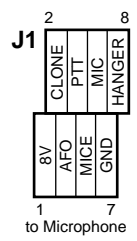
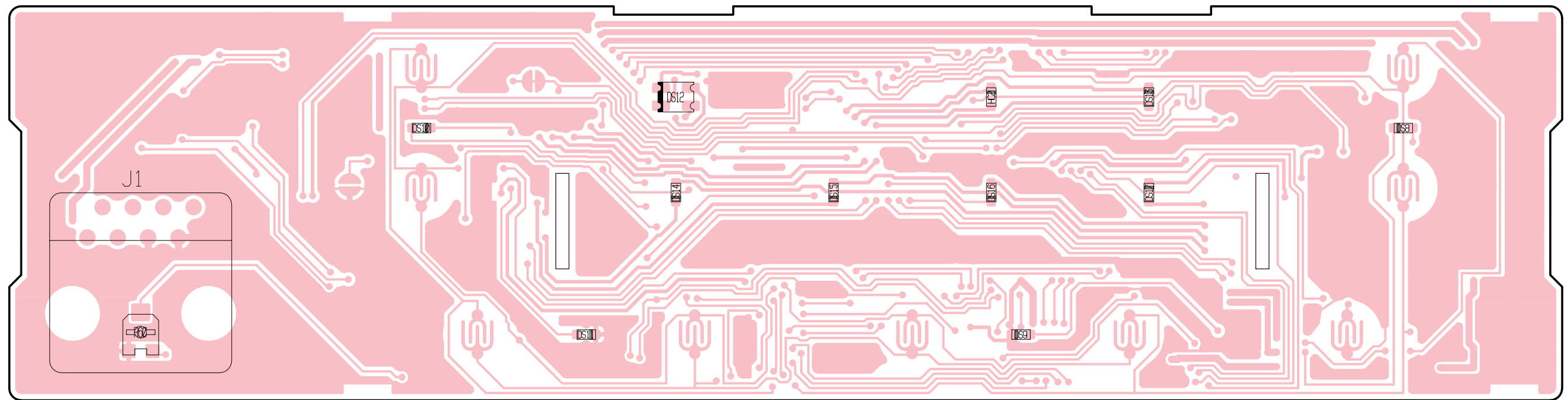

● BOTTOM VIEW

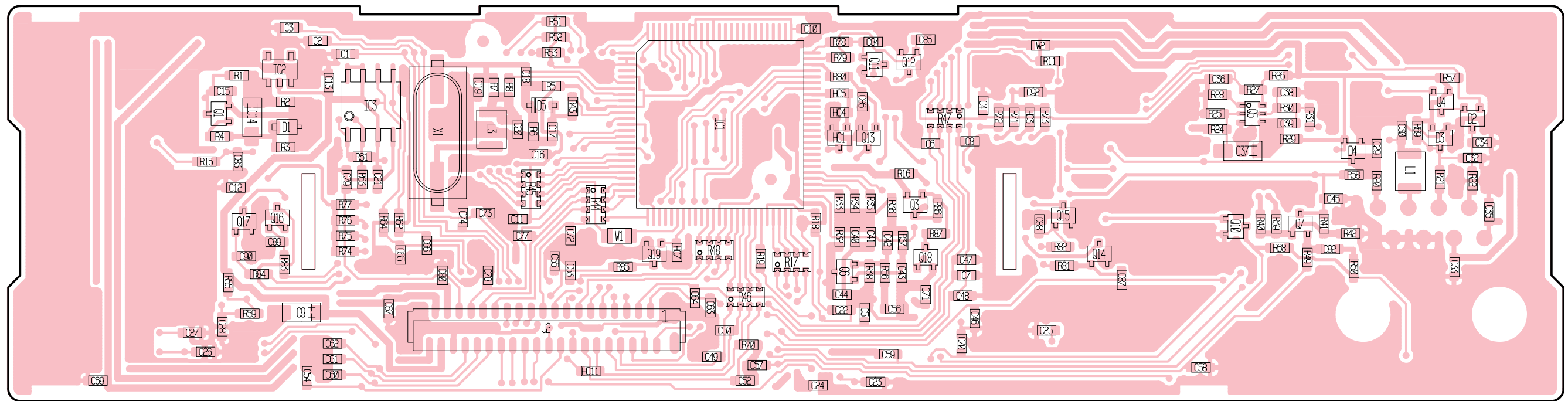

39	5V	AFO	SI	OPT3	OPT2	OPT1	OPV3	OPV2	OPV1	PIT	PTTN	DET	PWON	EXPTT	DIMIN	SO	SOK	SD	LVIN	GND	1
J2	8V	CPU5V	GND	OPINT	OPCS	BUSY	BEEP	BEFP	DTCSIN	RFATT	NOIS	UNLK	EXEN	EXST	DAST	PLST	VIN	TEMP	MIC	GND	2
40	to MAIN unit J1																				

9-3 MAIN UNIT (IC-F310/IC-F310S)

● TOP VIEW

1	PTTIN	15
2	PTTOUT	
3	MICOUT	
4	MICIN	
5	MICMUTE	
6	AFONOP	
7	BEEPOUT	
8	RXMUTE	
9	DET	
10	SIGOUT	
11	OPT1	
12	OPT2	
13	OPT3	
14	GND	
15	OPV3	
16	SI	
17	OPV2	
18	SCK	
19		
20		
21		
22		
23		
24		
25		
26		
27		
28		
29		
30		

to Optional unit

2	GND
1	HV

1	SP
2	SPGND

to Speaker

11	PTT
12	GND
13	IN
14	GND
15	DET
16	GND
17	AFO
18	GND
19	HORN
20	DIM
21	HV

to Optional cable

2	5V	40
3	AFO	
4	SI	
5	OPT3	
6	OPT2	
7	OPT1	
8	OPV3	
9	OPV2	
10	OPV1	
11	PTT	
12	PTTIN	
13	DET	
14	PWON	
15	EXPTT	
16	DIMIN	
17	SO	
18	SCK	
19	SO	
20	LVIN	
21	GND	
22		
23		
24		
25		
26		
27		
28		
29		
30		
31		
32		
33		
34		
35		
36		
37		
38		
39		

to FRONT unit

NOTE:
L19, 20, 21, 22 should be mounted as the appointed direction.

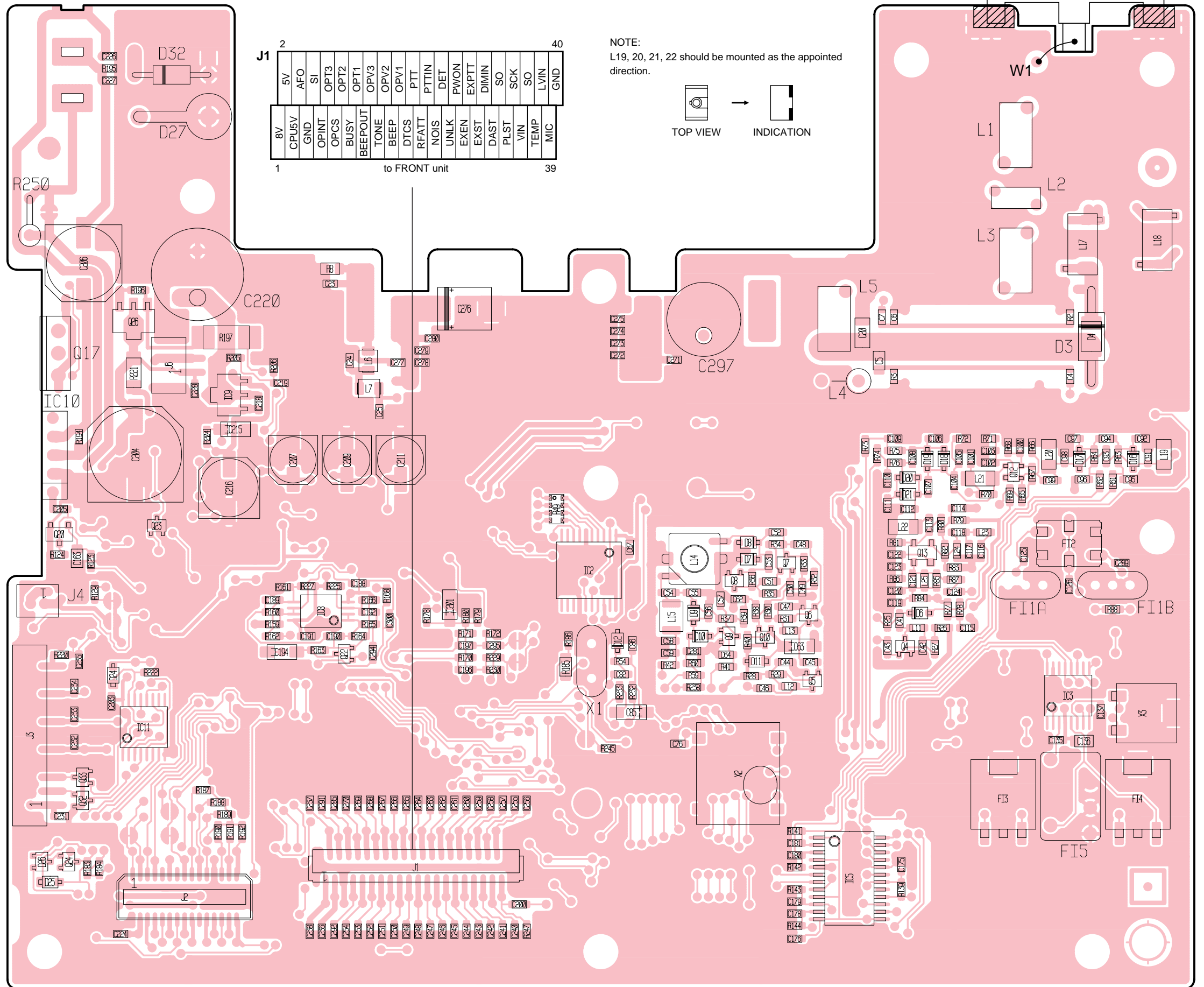
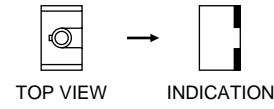

● BOTTOM VIEW

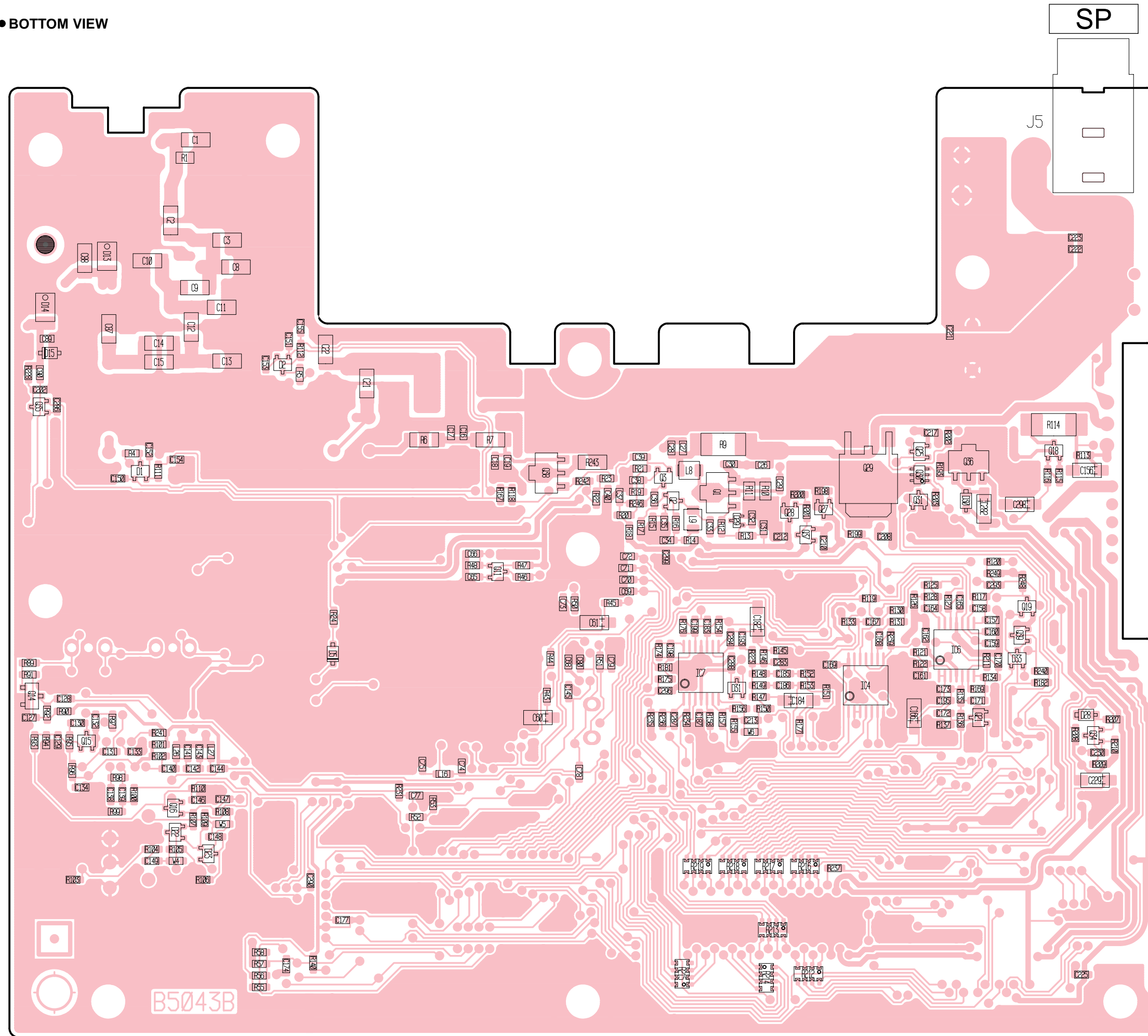

9-4 MAIN UNIT (IC-F320/F320S)

● TOP VIEW

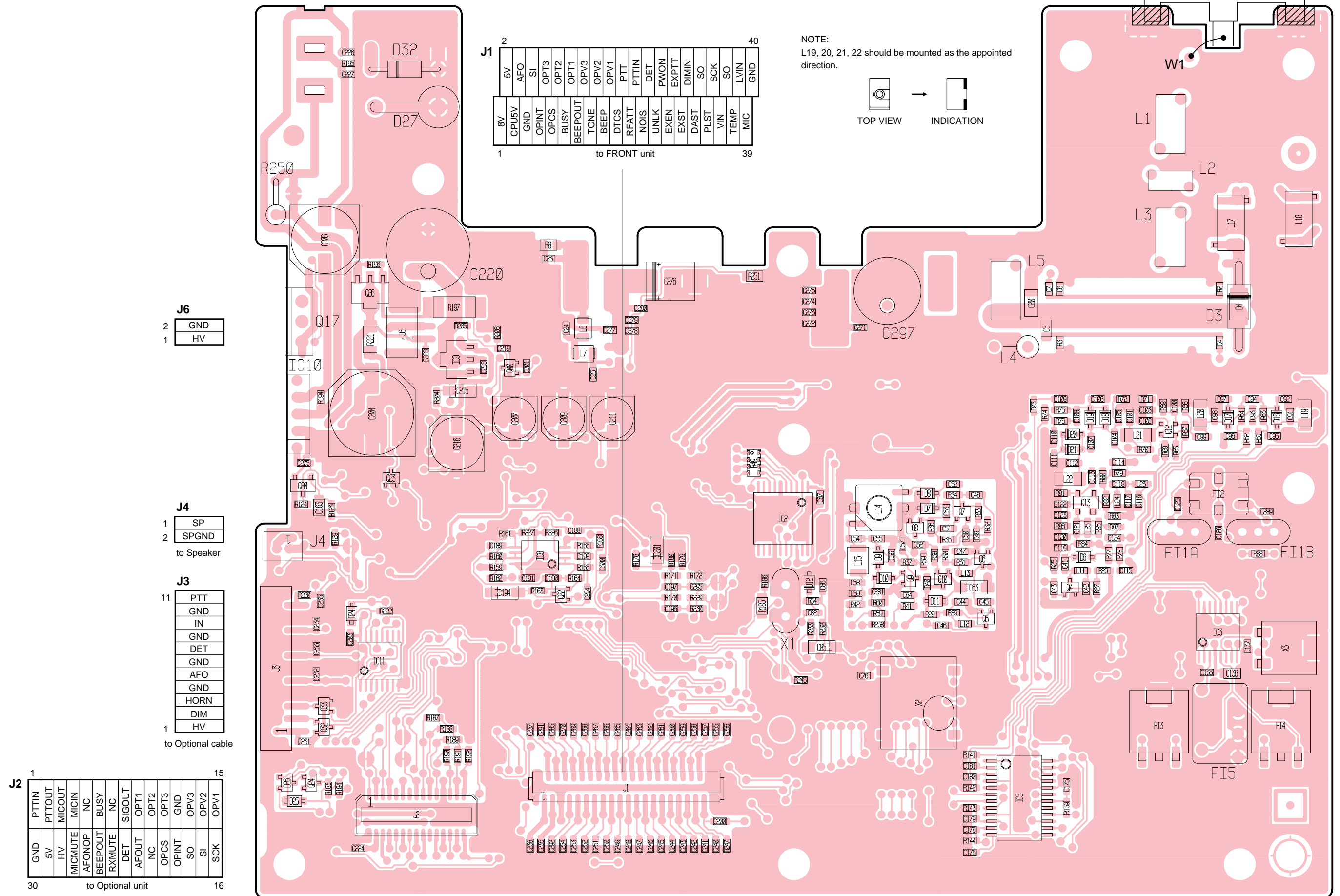

J1

1	8V	CPU5V	GND	OPINT	OPCS	BUSY	BEEP	BEFP	DTCS	NOIS	UNLK	EXEN	EXST	DAST	PLST	VIN	TEMP	MIC	39	
2	5V	AFO	SI	OPT3	OPT2	OPT1	OPV3	OPV2	OPV1	PTT	PTTIN	DET	PWON	EXPTT	DIMIN	SO	SCK	LVIN	GND	40

to FRONT unit

NOTE:
L19, 20, 21, 22 should be mounted as the appointed direction.

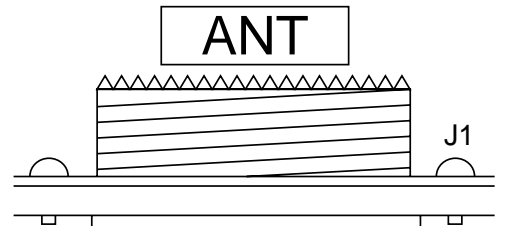

J6

2	GND
1	HV

J4

1	SP
2	SPGND

to Speaker

J3

11	PTT
	GND
	IN
	GND
	DET
	GND
	AFO
	GND
	HORN
	DIM
1	HV

to Optional cable

J2

30	GND	PTTIN	PTTOUT	5V	MICOUT	HV	MICIN	MICMUTE	AFONOP	BUSY	NC	BEEP	NC	BEFP	NC	DET	SIGOUT	AFOUT	OPT1	NC	OPT2	OPCS	OPINT	GND	SO	OPV3	SI	OPV2	SCK	OPV1	15
----	-----	-------	--------	----	--------	----	-------	---------	--------	------	----	------	----	------	----	-----	--------	-------	------	----	------	------	-------	-----	----	------	----	------	-----	------	----

to Optional unit

● BOTTOM VIEW

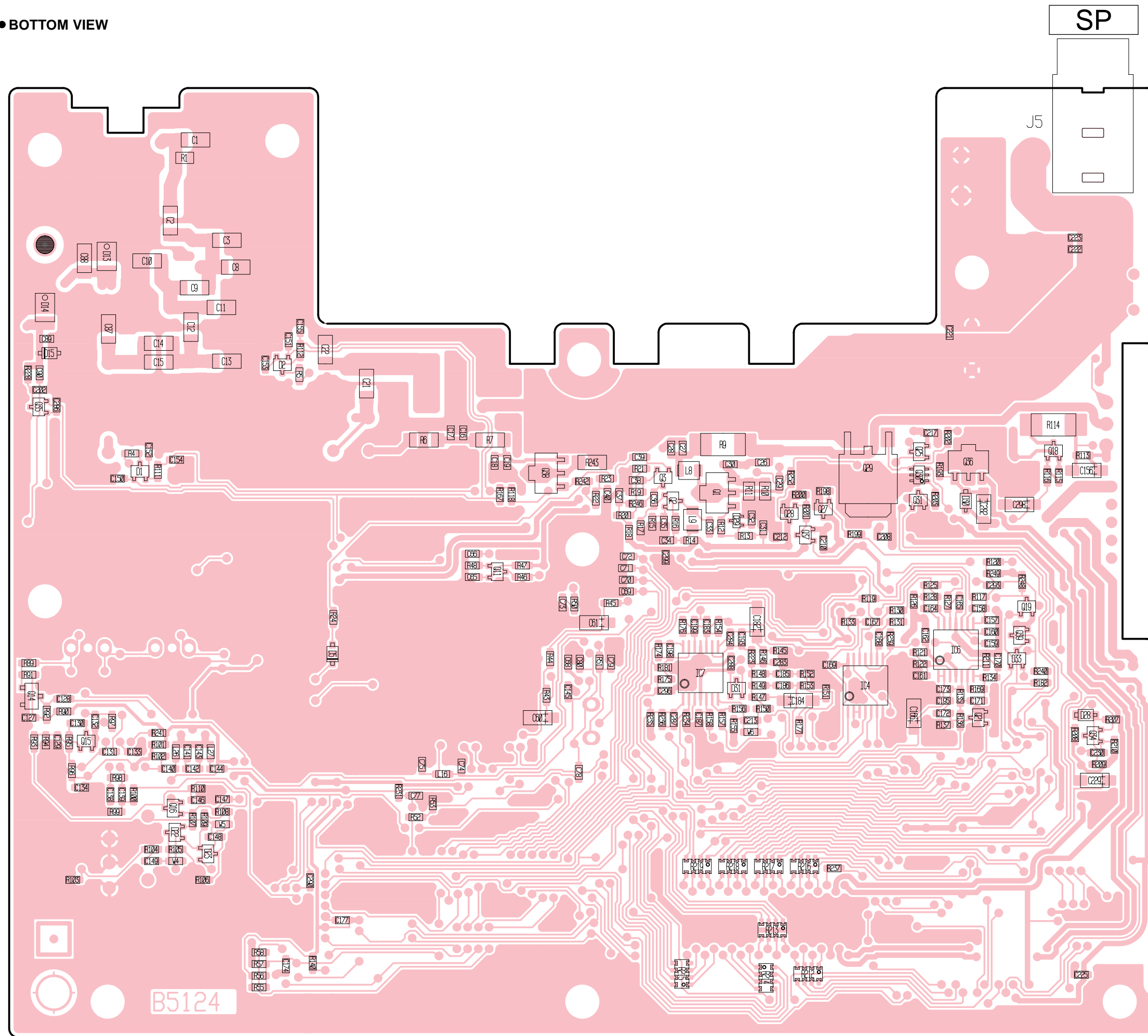

SECTION 10 BLOCK DIAGRAM

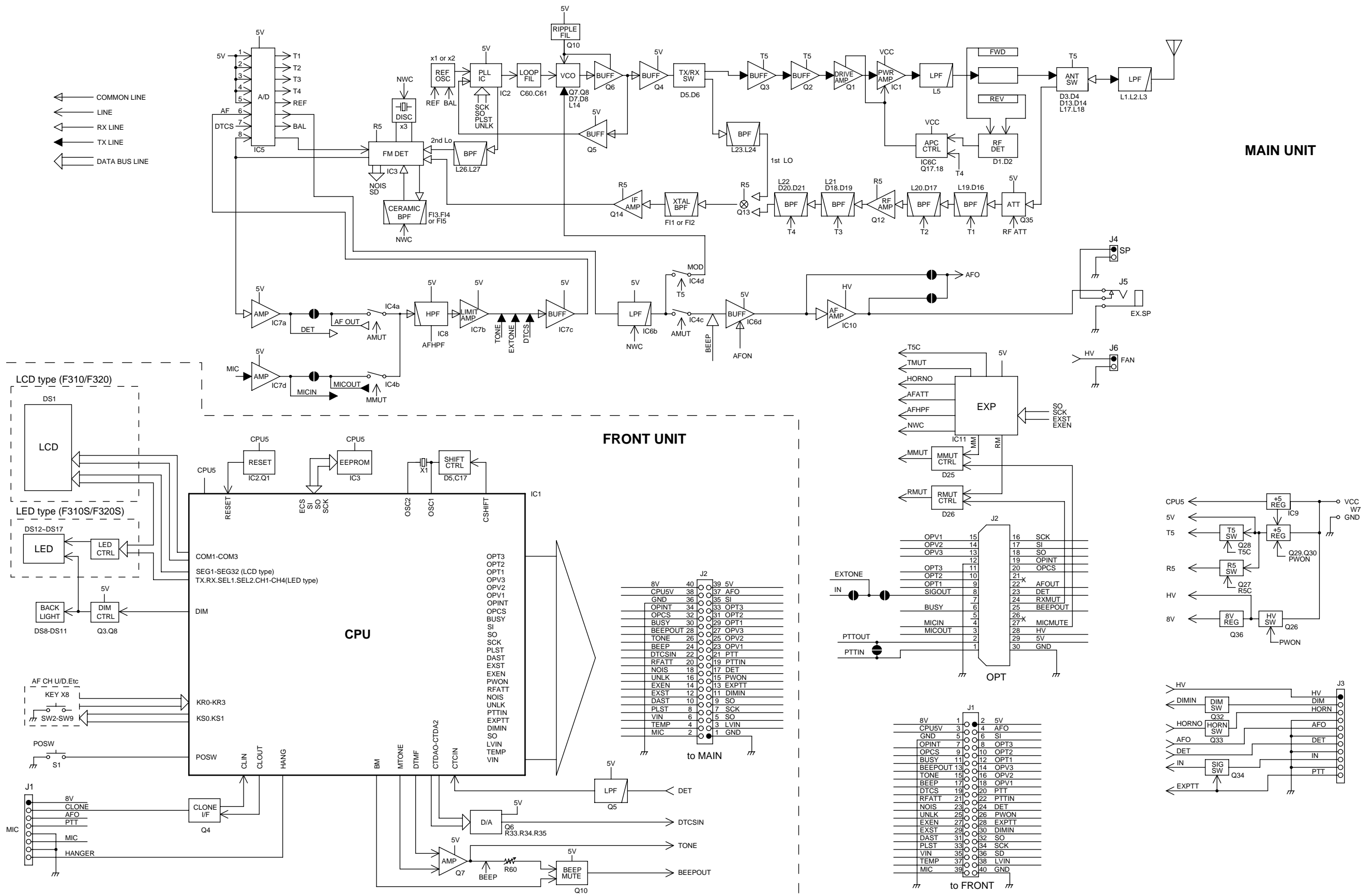

SECTION 11 VOLTAGE DIAGRAM

FRONT UNIT

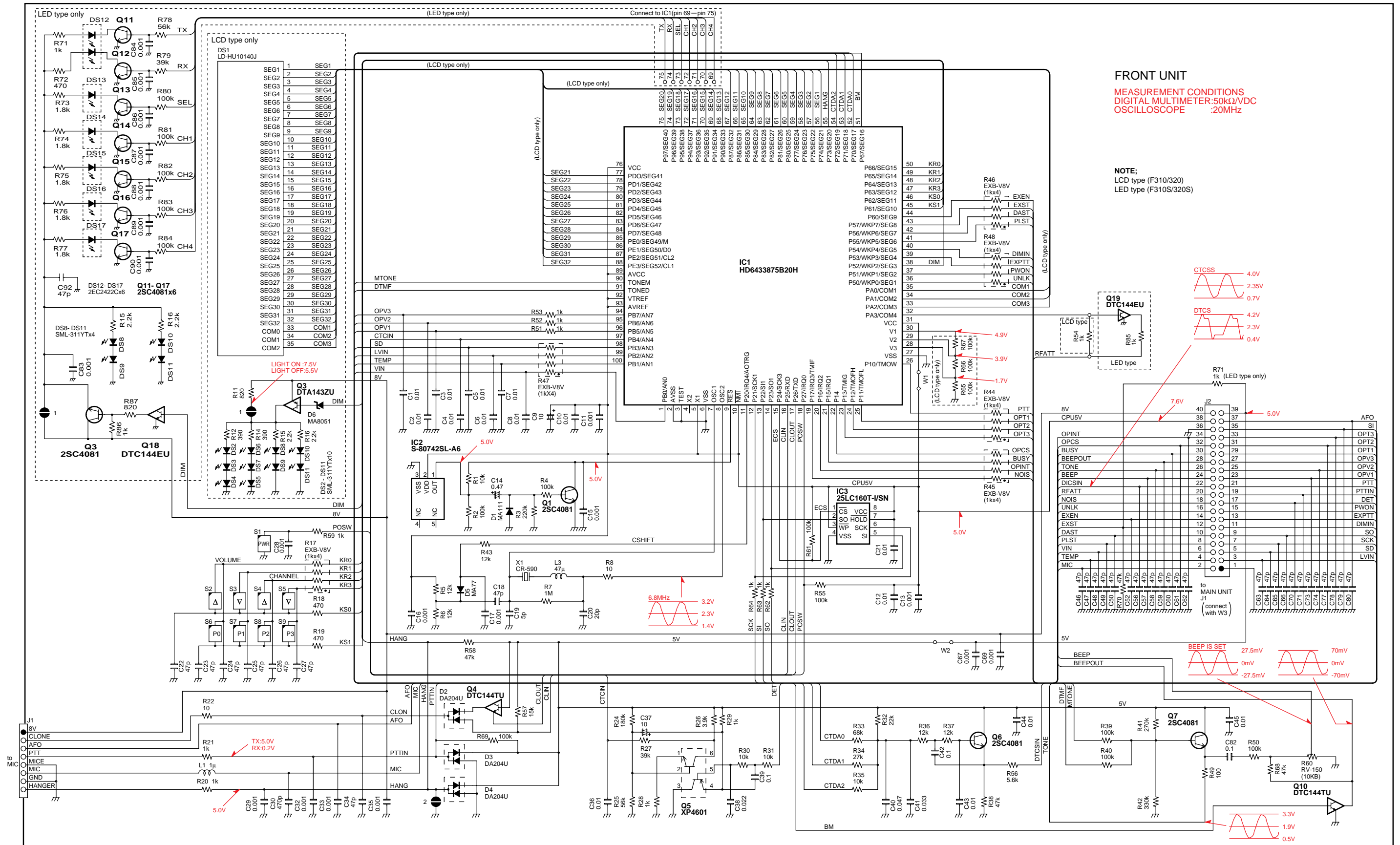

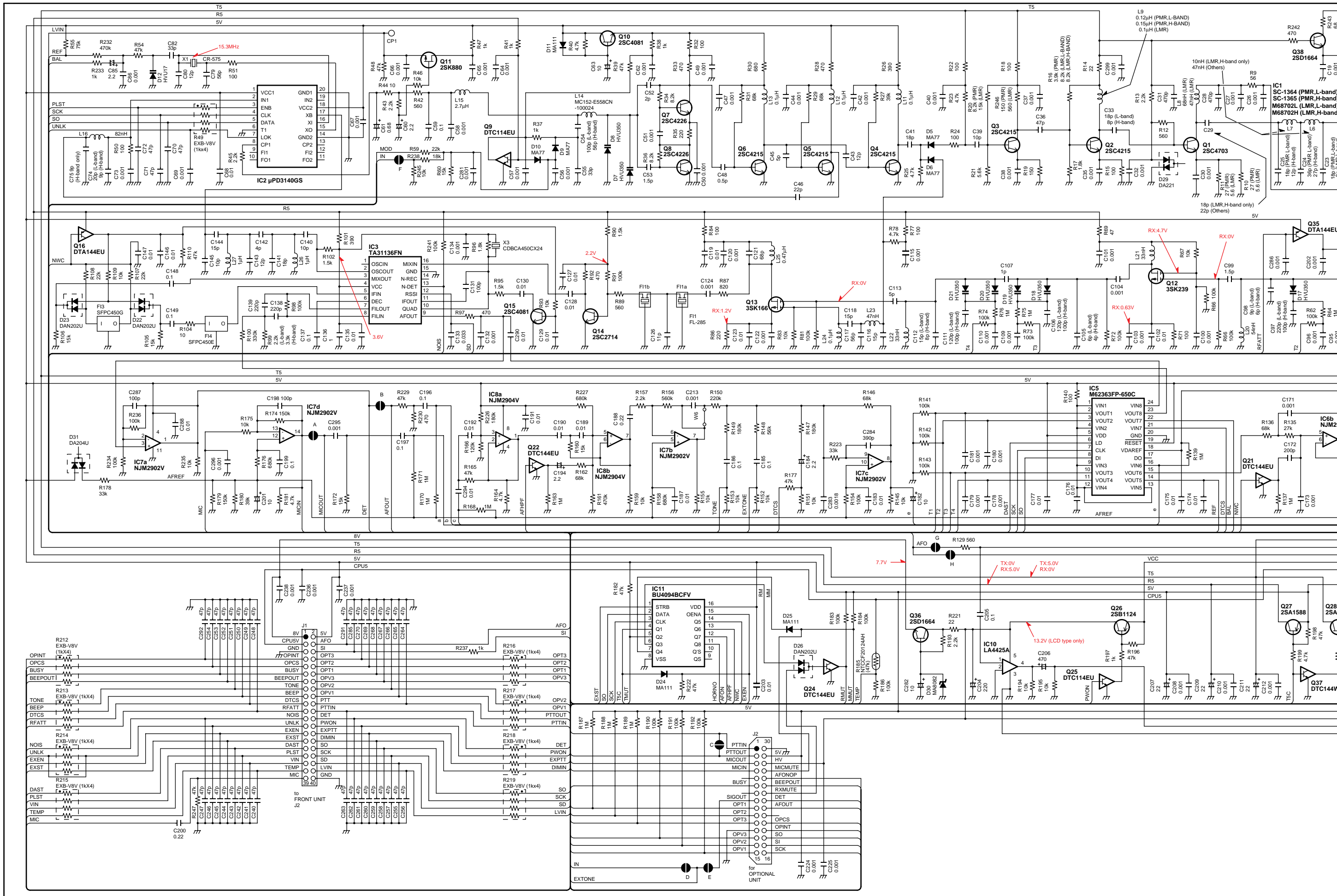

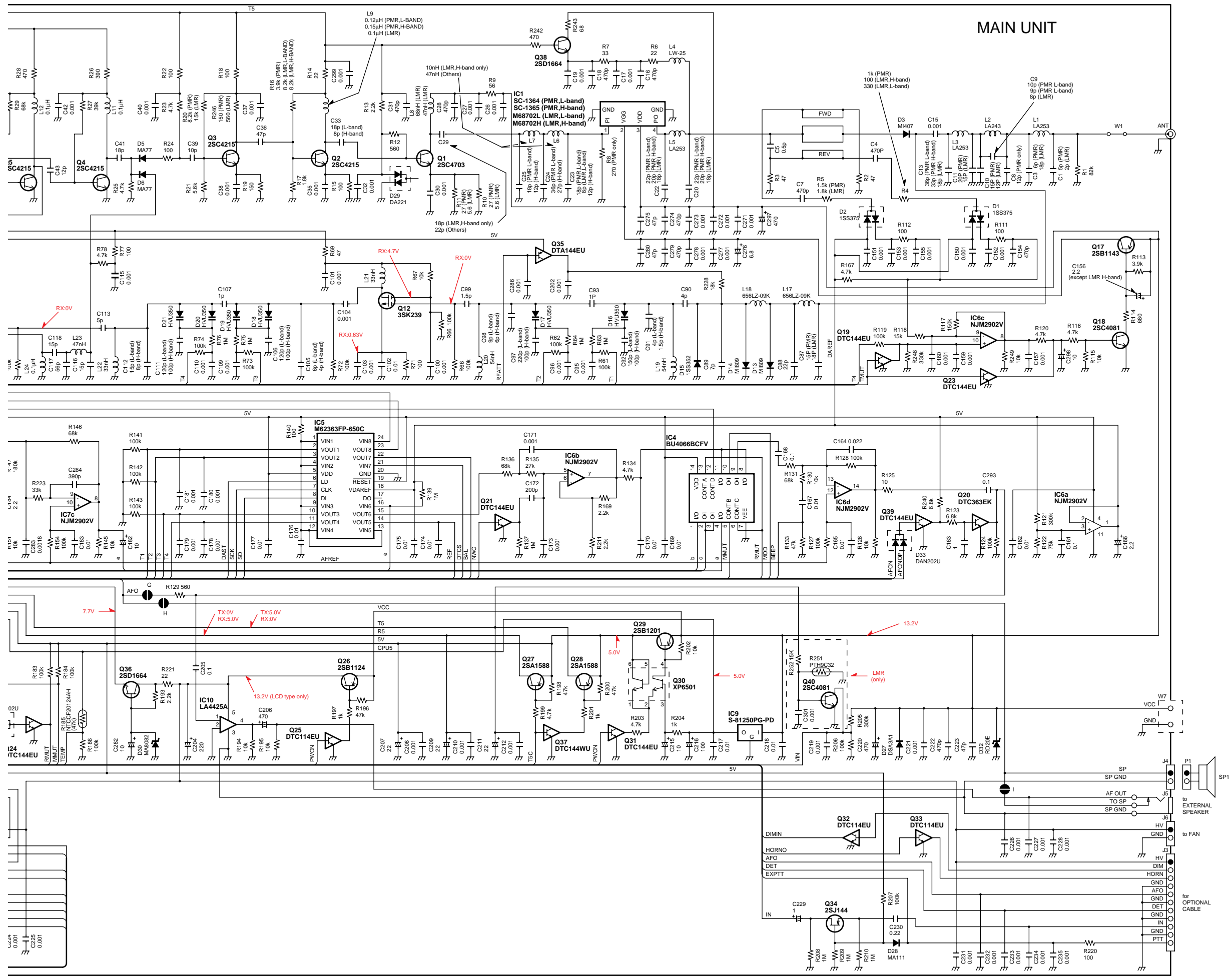

COMPLETE VIEW

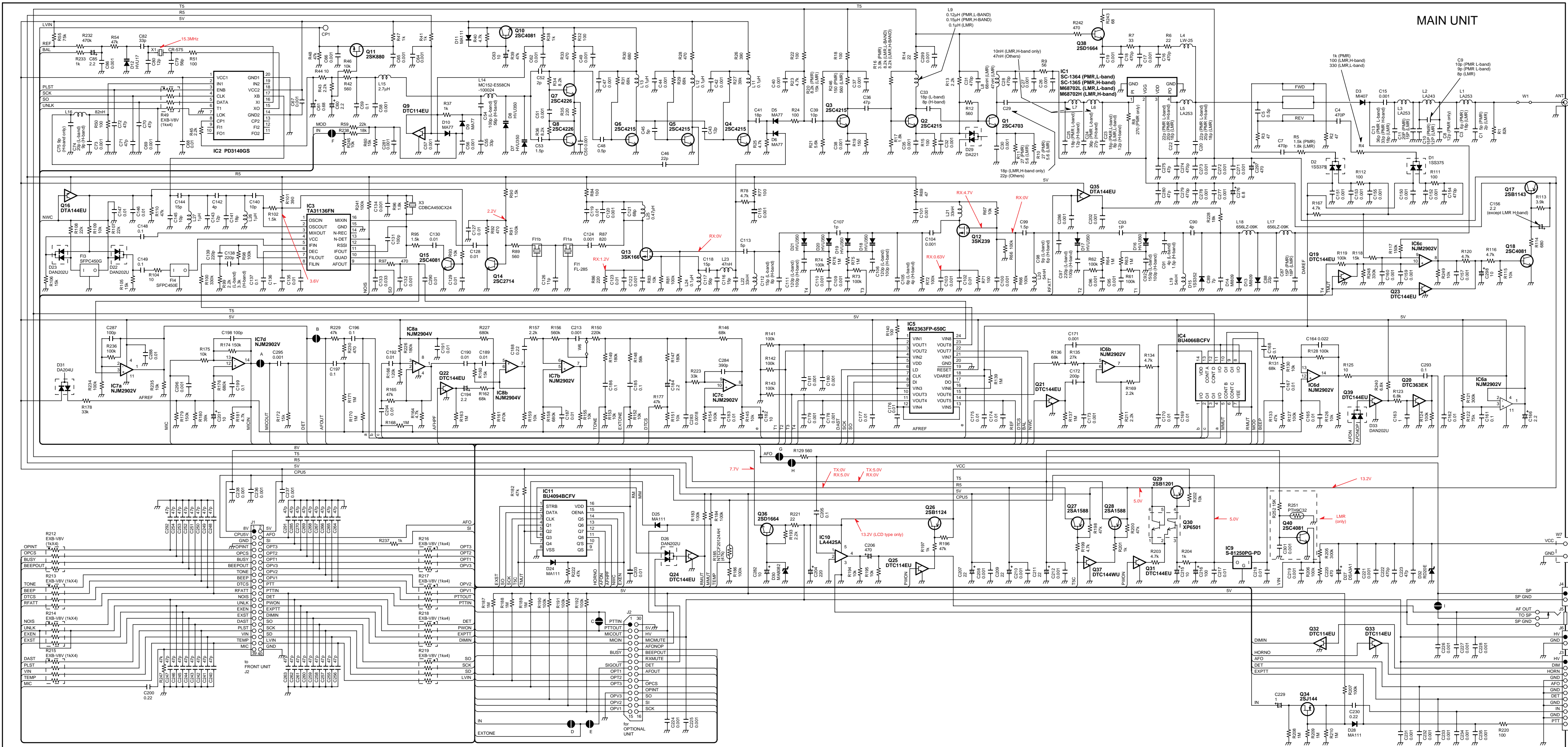

MAIN UNIT

Icom Inc.

1-1-32, Kamiminami, Hirano-ku, Osaka 547-0003, Japan
Phone : +81 (06) 6793 5302
Fax : +81 (06) 6793 0013
URL : <http://www.icom.co.jp/world/index.html>

Icom America Inc.

<Corporate Headquarters>
2380 116th Avenue N.E., Bellevue, WA 98004, U.S.A.
Phone : +1 (425) 454-8155 Fax : +1 (425) 454-1509
URL : <http://www.icomamerica.com>
<Customer Service>
Phone : +1 (425) 454-7619

Icom Canada

Glenwood Centre #150-6165
Highway 17 Delta, B.C., V4K 5B8, Canada
Phone : +1 (604) 952-4266 Fax : +1 (604) 952-0090
URL : <http://www.icomcanada.com>

Icom (Australia) Pty. Ltd.

A.B.N. 88 006 092 575
290-294 Albert Street, Brunswick, Victoria, 3056, Australia
Phone : +61 (03) 9387 0666 Fax : +61 (03) 9387 0022
URL : <http://www.icom.net.au>

Icom New Zealand

146A Harris Road, East Tamaki,
Auckland, New Zealand
Phone : +64 (09) 274 4062 Fax : +64 (09) 274 4708
URL : <http://www.icom.co.nz>

Beijing Icom Ltd.

1305, Wanshang Plaza, Shijingshan Road, Beijing China
Phone : +86 (010) 6866 6337 Fax : +86 (010) 6866 3553
URL : <http://www.bjicom.com>

Icom (Europe) GmbH

Communication Equipment
Himmelgeister Str. 100, D-40225 Düsseldorf, Germany
Phone : +49 (0211) 346047 Fax : +49 (0211) 333639
URL : <http://www.icomeurope.com>

Icom Spain S.L

Crta. de Gracia a Manresa Km. 14,750
08190 Sant Cugat del Valles Barcelona, SPAIN
Phone : +34 (93) 590 26 70 Fax : +34 (93) 589 04 46
URL : <http://www.icomspain.com>

Icom (UK) Ltd.

Unit 9, Sea St., Herne Bay, Kent, CT6 8LD, U.K.
Phone : +44 (01227) 741741 Fax : +44 (01227) 741742
URL : <http://www.icomuk.co.uk>

Icom France S.a

Zac de la Plaine, 1, Rue Brindejonc des Moulinais
BP 5804, 31505 Toulouse Cedex, France
Phone : +33 (5) 61 36 03 03 Fax : +33 (5) 61 36 03 00
URL : <http://www.icom-france.com>

Asia Icom Inc.

6F No. 68, Sec. 1 Cheng-Teh Road, Taipei, Taiwan, R.O.C.
Phone : +886 (02) 2559 1899 Fax : +886 (02) 2559 1874
URL : <http://www.asia-icom.com>

Count on us!

Icom Inc.

1-1-32, Kamiminami, Hirano-ku Osaka 547-0003, Japan

A-5560SZ-SV-②
© 1999-2003 Icom Inc.